

Evaporator			
Model	Dimensions W x D x H (inches)	Weight (lbs.)	Running Amps (with fan on "high")
4000Swc	16.6 x 12.6 x 22.1 (incl. mounting brackets)	42	8.6
4000Shwc	30.4 x 14.4 x 13.2 (incl. mounting bracket)	65	8.6
8000Swc	46.4 x 14.4 x 13.2 (incl. mounting bracket)	85	12.3

Condensing unit - Indoor			
Model	Dimensions W x D x H (inches)	Water Usage (gpm)	Weight (lbs.)
4000Swc, 4000Shwc	13.8 x 18.4 x 10.2	0.46	45
8000Swc	14.0 x 21.4 x 10.5	0.68	82

Evaporator

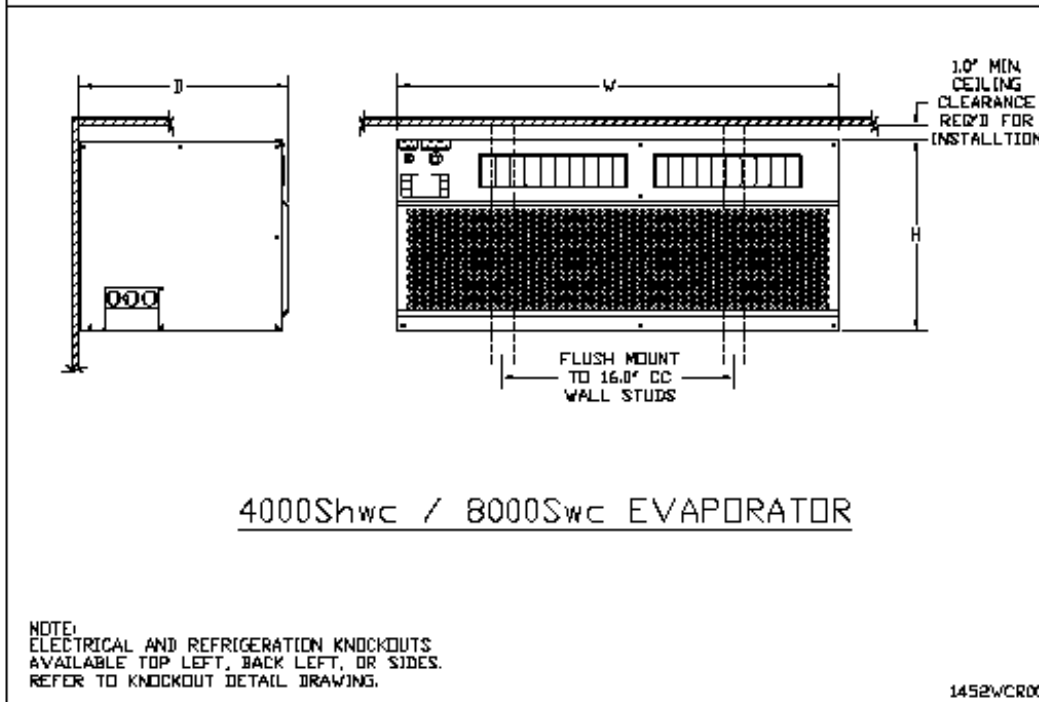
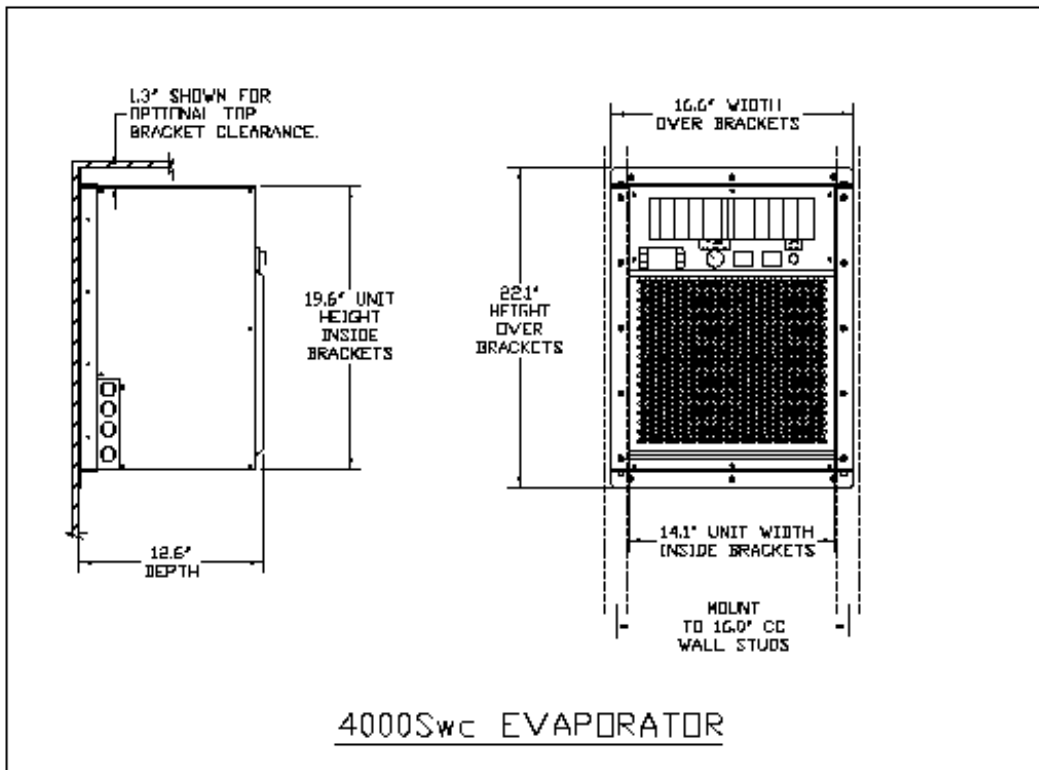

Condensing Unit

