



SPLIT Systems

Professional Grade
Split Cooling Systems



Installation, Operation and Maintenance Guide SP25, SP50, SP88, SP200

Manufactured by:

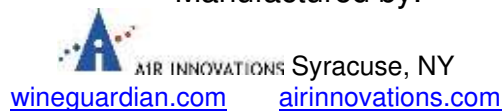

Wine Guardian reserves the right, without notice, to make changes to this document at its sole discretion. Please visit our web site for the most current version of the Wine Guardian PRO manual and other literature. Wine Guardian is a registered trademark (2,972,262) of Air Innovations, Inc. Revision 03-2021 © Wine Guardian PRO Split System

Part No. 15H0168-00 REV A



TABLE OF CONTENTS

| | |
|--|-------|
| Directory of Terms..... | 1 |
| Illustrations | 2 |
| Receiving, Inspecting and Unpacking the Wine Guardian PRO Split System | 4 |
| Review the Packing Slip to Verify | 4 |
| Check the fan coil unit for:..... | 4 |
| Check the condensing unit for..... | 4 |
| General Description..... | 5 |
| The Wine Guardian PRO Split System Contains..... | 5 |
| Wine Guardian PRO Split System Fan Coil Unit | 6 |
| Electrical Controls | 6 |
| Condensing Unit | 6 |
| Accessories and Optional Equipment..... | 7 |
| Heating Coils | 7 |
| Duct Collars and Flexible Ducts | 7 |
| Extended Compressor Warranty | 7 |
| Low Ambient Option..... | 7 |
| Condensate Pump | 7 |
| Humidifier..... | 7 |
| Overview of the PRO Split System fan coil..... | 8 |
| Wine Guardian PRO Split System specifications sheet..... | 13 |
| Wiring Diagram for SP25 and SP50 Units | 15 |
| Wiring Diagram for SP88 Units | 16 |
| Wiring Diagram for SP200 Units | 17 |
| Control Wiring diagram for SP25 & SP50..... | 17 |
| Control Wiring diagram for SP88..... | 19 |
| Control Wiring diagram for SP200..... | 20 |
| Split system wiring diagrams..... | 20-22 |
| Safety | 24 |
| Safety Message Conventions | 24 |
| Danger..... | 24 |
| Warning | 24 |
| Caution | 24 |
| Lockout/Tagout Procedure..... | 25 |
| Safety Considerations | 25 |
| Safety Hazards | 25 |

| | |
|--|-----------|
| Electrical Hazards | 25 |
| Electrical Shock Hazards | 25 |
| Hot Parts Hazards..... | 25 |
| Moving Parts Hazards..... | 25 |
| Equipment Safety Interlocks..... | 26 |
| Main Power Switch..... | 26 |
| Installation | 27 |
| Pre-installation Test | 28 |
| Air Flow Diagram | 28 |
| Planning the Installation | 29 |
| Addressing Items in the Planning Process | 30 |
| Performing a Pre-installation Check..... | 30 |
| Installing the Fan Coil Unit | 30 |
| Floor Mounting..... | 31 |
| Wall Mounting | 31 |
| Ceiling Mounting | 31 |
| Typical Mounting Arrangements | 32 |
| Handling and Installation..... | 32 |
| Floor Mount Fig 1..... | 32 |
| Rod/Ceiling Mount Fig 2..... | 33 |
| Shelf/Wall Mount Fig 3..... | 33 |
| Optional ductwork connection on same wall Fig. 4..... | 33 |
| Installing the Ductwork and Grilles | 34 |
| Duct Collars | 34 |
| Location of Supply and Return Grilles | 34 |
| General Duct Recommendation | 35 |
| Reducing Noise from the Unit | 35 |
| Installing the Condensate Drain Connection | 36 |
| Installing the Drain Line..... | 36 |
| Priming the Drain Trap..... | 36 |
| Wiring the Fan Coil Unit for Power | 37 |
| Installing the Condensing Unit..... | 38 |
| Installation of Interconnecting Refrigerant Lines (Suction and Liquid) | 38 |
| Split System Interconnecting Line Sizing Chart..... | 39 |
| Sample Piping Configurations | 40 |
| Leak Checking and Evacuation Process | 41 |
| Wiring | 41 |
| Refrigerant Charging..... | 42 |

| | |
|---|-----------|
| Determining the amount of charge | 42 |
| Procedures for Charging System with Head Pressure Control | 43 |
| Superheat | 44 |
| Sub-Cooling | 44 |
| System charging Amount and examples | 44-45 |
| Additional charge for XLA option | 45 |
| Split System Operations Chart | 46 |
| Inspection and Start Up Checklists | 48 |
| Receiving and Inspecting | 48 |
| Handling and Installing | 48 |
| Starting-up the Unit | 48 |
| Starting-up and Operating the Wine Guardian PRO Split System | 49 |
| Turn on the Unit | 49 |
| Testing the Fan | 49 |
| Running the Unit | 49 |
| Cycling the Unit | 50 |
| Setting the Remote Interface Controller | 50 |
| Regulating the Wine Room Temperature | 50 |
| Changing the Air Flow Direction | 50 |
| Maintenance | 51 |
| General | 51 |
| Cleaning the Condensate Drain System | 52 |
| Cleaning the Humidifier | 52 |
| Heating Coil Option | 52 |
| Maintenance Schedule | 53 |
| Monthly | 53 |
| Yearly | 53 |
| Troubleshooting | 54 |
| Typical start up problems | 54 |
| Unit does not start up | 54 |
| Power switch light is on and the remote interface controller light is off | 54 |
| Power switch light is on and the remote interface controller light is on | 54 |
| Unit is operating and blows evaporator air, | 55 |
| Room temperature too cold (below 51 degrees) when unit is running | 55 |
| Room temperature too cold (below 51 degrees) when unit is not running | 55 |
| Humidity too low or supply air is too cold, without optional humidifier | 55 |
| Humidity too low, without optional humidifier | 56 |
| Humidity too low, with optional humidifier | 56 |

| | |
|--|-----------|
| Humidity too high when unit is running but not cooling | 56 |
| Humidity too high when unit is not running | 56 |
| Humidity too high when unit is running and cooling | 56 |
| Unit operates but the power switch light is not ON | 57 |
| Unit is leaking water | 57 |
| Unit is running properly, but the sound of the unit objectionable..... | 57 |
| High Pressure Switch has Shut the Unit Down | 58 |
| Instructions to Reset High Pressure Switch | 58 |
| Advanced Troubleshooting..... | 59 |
| Evaporator Coil is Freezing | 59 |
| High pressure switch keeps tripping..... | 59 |
| Unit cycles on and off more than 8 times/hr | 59 |
| High pitched or loud rubbing noise, clanking or vibration..... | 59 |
| Replacing the blowers..... | 59 |
| Contact and Warranty Information | 60 |
| Contact Information..... | 60 |
| Warranty and Warranty Procedure | 60 |
| Warranty | 61 |

Directory of Terms

Ambient Air – The surrounding area outside the wine room such as a room, basement, garage or outdoors.

BTU/H – British thermal units/hour. A unit of measurement to describe the power of heating and cooling system.

CFM – Cubic feet per minute. A unit of measurement for the amount of air handled by the fan.

Condensate / Condensation – The water formed out of the air when it is cooled below a certain temperature (called dew point). Often referred to as “sweating” on pipes and cold surfaces. This water collects at the bottom of the evaporator or cooling coil and drains out of the unit through the drain line.

Condensing Unit (Heat Rejection) – The condensing unit uses the compressor, condenser coil and fan to remove heat from the refrigerant to the ambient air *outside* the wine room. The word condenser refers to the condensation of the refrigerant from gas to liquid phase.

CSA/ETL – Canadian Standards Association/Edison Testing Laboratory (product compliance to safety standards)

F – (Degrees) Fahrenheit

Fan Coil Unit (Evaporator Cooling) – The fan coil unit uses the cooling coil and the fan to remove heat from the air *inside* the wine room to the refrigerant, cooling the air and condensing moisture out of the air. The word evaporator refers to the evaporation of the refrigerant from liquid to gas phase in the coil. The fan coil unit is ducted to or can be placed inside the wine room.

Flexible Duct – Round ducts with steel reinforced plastic liners, a layer of insulation and an outer plastic layer used to convey the air from the unit to the wine room or ambient space.

Grille or Diffuser – Inlet or outlet plates to direct the airflow or protect the inside of the unit.

Heat Gain / Loss – The amount of cooling or heating expressed in watts transferred between the wine room and the ambient space. The PRO Split System must offset this heat/gain loss.

Inlet Air – The air returning from the wine room to the PRO Split System fan coil.

I.D. – Inside diameter

NEC – National Electrical Code

O.D. – Outside diameter

Psig Pounds – Force per square inch gauge

Recovery – The amount of cooling the unit does to return the room to its set point temperature after some new heat load is introduced, such as people or new cases of warm wine entering the room.

Return Air - The air leaving the room and returning to the inlet of the fan coil. (See Inlet Air above)

TXV – Thermal expansion valve

VAC – Volts alternating current

SP – Static pressure. Unit of measurement (inches of water column) of the pressure of the air handled by the fan.

Set Point – The desired temperature or humidity set on the remote interface controller or humidistat.

Supply Air - The air entering the wine room from the discharge of the fan coil.

Illustrations

| | |
|--|-------|
| Overview of the PRO Split System Fan coil | 7 |
| Refrigeration Illustration of the PRO Split System fan coil..... | 7 |
| Low volt connections..... | 8 |
| Overview of ProSeries Condensing unit..... | 9 |
| Split system piping schematic..... | 10 |
| Condensing unit refrigeration drawing..... | 11 |
| Split system dimensions..... | 12 |
| Wine Guardian PRO Split System specifications sheet..... | 13 |
| Wiring diagrams for SP25 and SP50 units | 14 |
| Wiring diagram for the SP88 unit | 15 |
| Wiring diagram for the SP200 unit | 16 |
| Control wiring..... | 17-19 |
| Split systems wiring schematics..... | 20-22 |
| Airflow diagram | 27 |
| Mounting illustrations..... | 31-32 |
| Sample piping illustration | 39 |

Receiving, Inspecting and Unpacking the Wine Guardian PRO Split System

NOTE: Wine Guardian PRO Split Systems are factory assembled and tested prior to shipment. The PRO Split System consists of two separate components, the fan coil and condensing unit.

Each PRO Split System component is shipped in a corrugated box. A shipment may include one or more boxes containing accessories.

- ✓ Lift at the designated handhold locations only or fully support from underneath.
- ✓ Before opening, inspect the packing crates or boxes for obvious signs of damage or mishandling.
- ✓ Write any discrepancy or visual damage on the bill of lading before signing.
- ✓ Inspect all equipment for any sign of damage caused during transit.
- ✓ Report all visual or concealed damage to the carrier and file a claim immediately.
- ✓ Thoroughly inspect the contents for any visible damage or loose parts.

IMPORTANT

If this procedure is not followed, the shipping company may reject the claim and the consignee may suffer the loss. Do not return the shipment to the factory.

Review the Packing Slip to Verify

- ✓ Model number
- ✓ Factory installed options
- ✓ Unit accessories

If any items listed on the packing slip do not match your order information, contact the place of purchase immediately.

Check the fan coil unit for:

- ✓ An electrical power cord connected to the fan-coil
- ✓ 7' of clear plastic drain line for connection to the fan-coil
- ✓ One supply duct collar and one return duct collar
- ✓ Plastic bag with quick start manuals – Keep for your records

Check the condensing unit for:

- ✓ condensing unit complete with outdoor enclosure

General Description

View Fig. 1 and Fig. 2 starting on page 7 for details

IMPORTANT
Design and specifications are subject to change without notice

The PRO Split System is a professional grade, American-manufactured, split two-piece climate control unit designed specifically for the storage of wine at wine room temperatures. It is designed for easy installation and operation. Wine Guardian PRO Split System uses 24 volt controls and R-134a refrigerant. The entire PRO Split System fan coil and condensing unit sections are tested at the factory. All components are of a high quality standard commercial grade. The entire system is approved by ETL according to UL 1995 and CSA safety standards. All wiring complies with NEC. Each PRO Split System fan coil section is furnished with a sealed, UL-approved power cord and plug.

The Wine Guardian PRO Split System Contains

1. **A Wine Guardian PRO Split System Fan Coil Unit with:**

- ✓ A thermal expansion valve to control the flow of refrigerant into the evaporator coil
- ✓ A built-in condensate drain trap. No external trap is required.
- ✓ A removable control panel for ease of service
- ✓ Supply duct collar
- ✓ Return duct collar
- ✓ 24 volt terminal strip for connection to standard thermostats/humidistats

2. **A Condensing Unit with:**

- ✓ A filter dryer to keep the refrigerant clean and free of contaminants
- ✓ A sight glass to observe the level of refrigerant
- ✓ A manual reset high pressure switch on the discharge to protect the compressor from high pressures.
- ✓ Auto reset low pressure switch
- ✓ 24-volt contactor for control of fan coil unit
- ✓ Crankcase heater
- ✓ Low ambient refrigeration controls
- ✓ Outdoor enclosure

PRO Split System Fan Coil Unit

The PRO Split System fan coil unit meets its rated capacities for total BTU/H and CFM at design room conditions and external static pressures. The fan coil unit is capable of rated CFM against the static pressure imposed by recommended ductwork. The fan is a motorized impeller type, statically and dynamically balanced, and uses permanently lubricated direct drive motors requiring no maintenance.

The PRO Split System fan coil section operates as air passes through the cooling coil and is cooled by the refrigerant inside the coil. This causes any excess humidity in the air to condense and be captured in the drain pan and piped outside the unit. Air then enters the fan where it is pressurized and discharged out of the unit through one of five openings. Optional heating coils are located between the cooling coil and the fan. These coils heat the air to prevent low temperatures in the wine room.

All exterior framing of the PRO Split System is powder coated 0.063 inch gauge aluminum to prevent rust and corrosion. All coils are aluminum tubes, aluminum fins to protect against premature corrosion. The unit uses an external drain to remove excess moisture and not reintroduce it into the room or ambient space. Removable, multiple access doors are provided to facilitate cleaning and maintenance, duct connections, and access to components and wiring. The fan coil has at least five discharge outlets to facilitate custom installations.

Each unit is provided with a 24 volt terminal strip for connection to most standard 24 volt thermostats or humidistats. A thermostat is not provided as standard equipment.

Electrical Controls

The main electrical control components are located on a separate panel accessible through a side door panel or by removal of the on/off panel from the system chassis. All wiring is in accordance with the NEC. Wires are numbered and color coded to match the wiring diagrams.

Electric power is supplied by a single factory-furnished cord and plug.

Condensing Unit

Compressors are rotary, self-lubricating, permanently sealed, hermetic reciprocating-type compressors, with internal overload protection and capacitor start. They include a minimum of 20 months manufacturer's warranty and an optional two-year warranty. Compressors are mounted on rubber-in-shear isolators to reduce noise and vibration. Additional features include a liquid line filter drier, Head Master Controls, a liquid line receiver, refrigerant sight glass, manual reset high pressure switch and auto reset low pressure switch. Each unit is housed in a painted aluminum enclosure suitable for outdoor installation. The outdoor enclosure has an integral fan for air movement across the condenser coil, pre-drilled penetrations for electrical connections and external king valves for ease of refrigerant piping connections.

IMPORTANT

The air exhaust from the condensing unit is hot and will be 25 to 35 degrees F above the entering temperature. The condensing units are rated for a maximum temperature of 115 degrees F. The condensing units should be installed in a well-ventilated area to ensure proper air flow across the condenser coil and to limit short cycling.

Accessories and Optional Equipment

Heating Coils

An optional heating coil is built in and requires no additional power source. The electric heating option is factory installed and includes primary and secondary over-temperature protection devices per UL and NEC.

Duct Collars and Flexible Ducts

Ducting for the Wine Guardian PRO Split System is sold in kits by size for each unit. Each kit contains two adapter collars, one 25-foot length of round flexible duct and two straps. The number of duct kits needed depends on the wine room layout and application. The size of the kit depends on the model Wine Guardian PRO Split System selected. Follow installation instructions carefully. Poorly or incorrectly installed ducts can degrade the performance of your unit dramatically.

Extended Compressor Warranty

The Wine Guardian PRO Split System uses only the best commercially available compressors on the market. However, since the compressor is the single most expensive component in the unit, it is recommended that you purchase the extended warranty option.

Low Ambient Option – Standard on all Wine Guardian PRO Split Systems

A factory-installed low ambient option is available that makes the Wine Guardian PRO Split System capable of exposure to low ambient temperatures. This feature controls the condenser fan operation based on head pressure and heats the compressor oil reservoir. The low ambient option is recommended whenever the condenser section is exposed to air temperatures below 40 degrees F. to a minimum of 20 degrees F.

Extreme Low Ambient Option

A factory installed extreme low ambient option is available that makes the Wine Guardian Pro Split System capable of exposure to temperatures as low as -20 Deg F (-29 Deg C) . This feature includes the addition of a receiver heater, an adjustable timer for low pressure cutout, fan cycling switch, check valve and thermostat. The Extreme Low Ambient Option is recommended whenever the condenser section is exposed to air temperatures below 20 Deg F (-7 Deg C) to a minimum of -20 Deg F (-29 Deg C).

Condensate Pump

An optional Wine Guardian PRO Split System automatic condensate pump is available to pump the water to a remote sink, drain pipe or outside. It requires a separate 120-volt electrical outlet.

Humidifier

Another popular option for the Wine Guardian PRO Split System is a humidifier. The humidifier is available for split system installation and can be retrofitted onto any existing Wine Guardian PRO Split System unit. Each humidifier is furnished with a communication cable connection to plug into the side of the Wine Guardian PRO SERIES System fan coil unit. It can then be controlled by any 24 volt humidistat or combination thermostat/humidistat device. The humidifier mounts directly onto the Wine Guardian PRO Split System unit and requires a water supply and drain for operation.



**CAREFULLY FOLLOW THE INSTALLATION INSTRUCTIONS INCLUDED WITH THE HUMIDIFIER.
REFER TO THE INSTRUCTIONS CONTAINED IN THE BOX FOR THE HUMIDISTAT.**

Overview of the Wine Guardian PRO SERIES Split System fan

Fig. 1

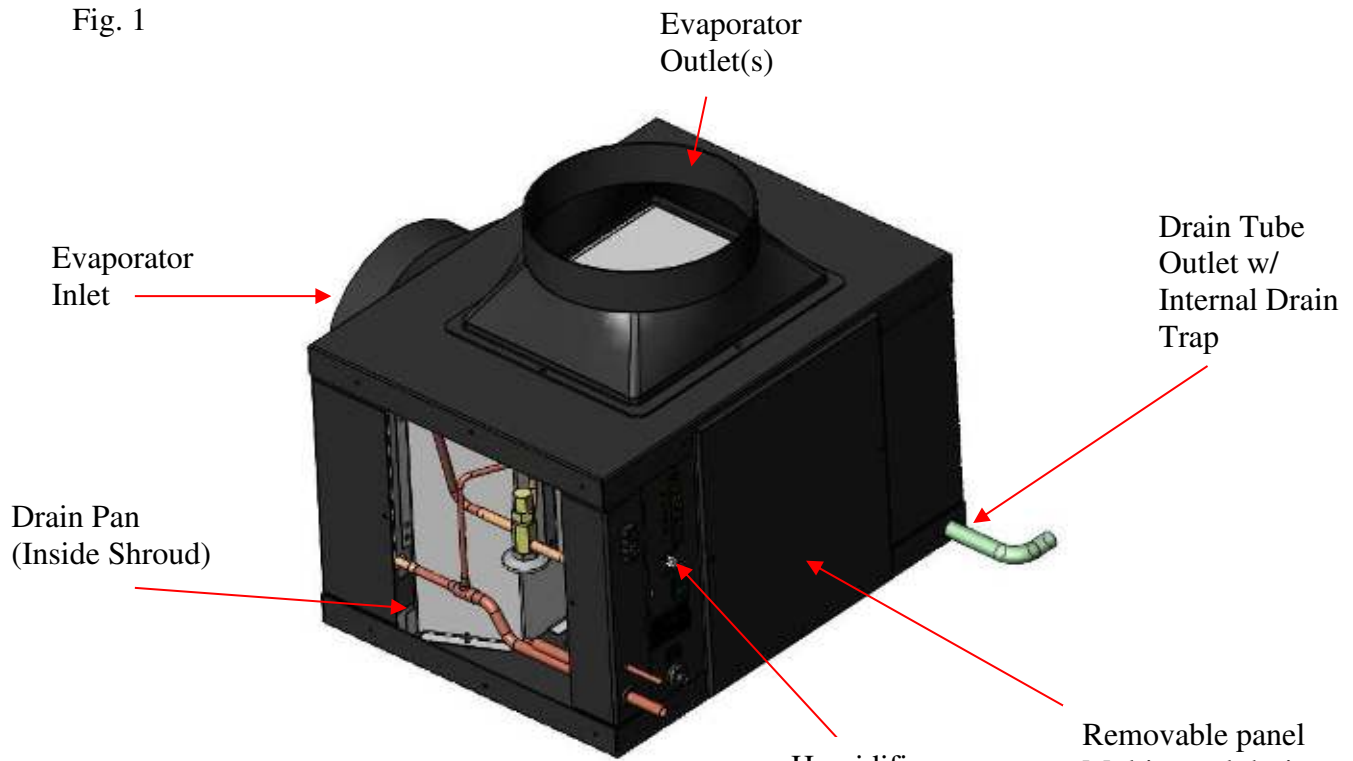
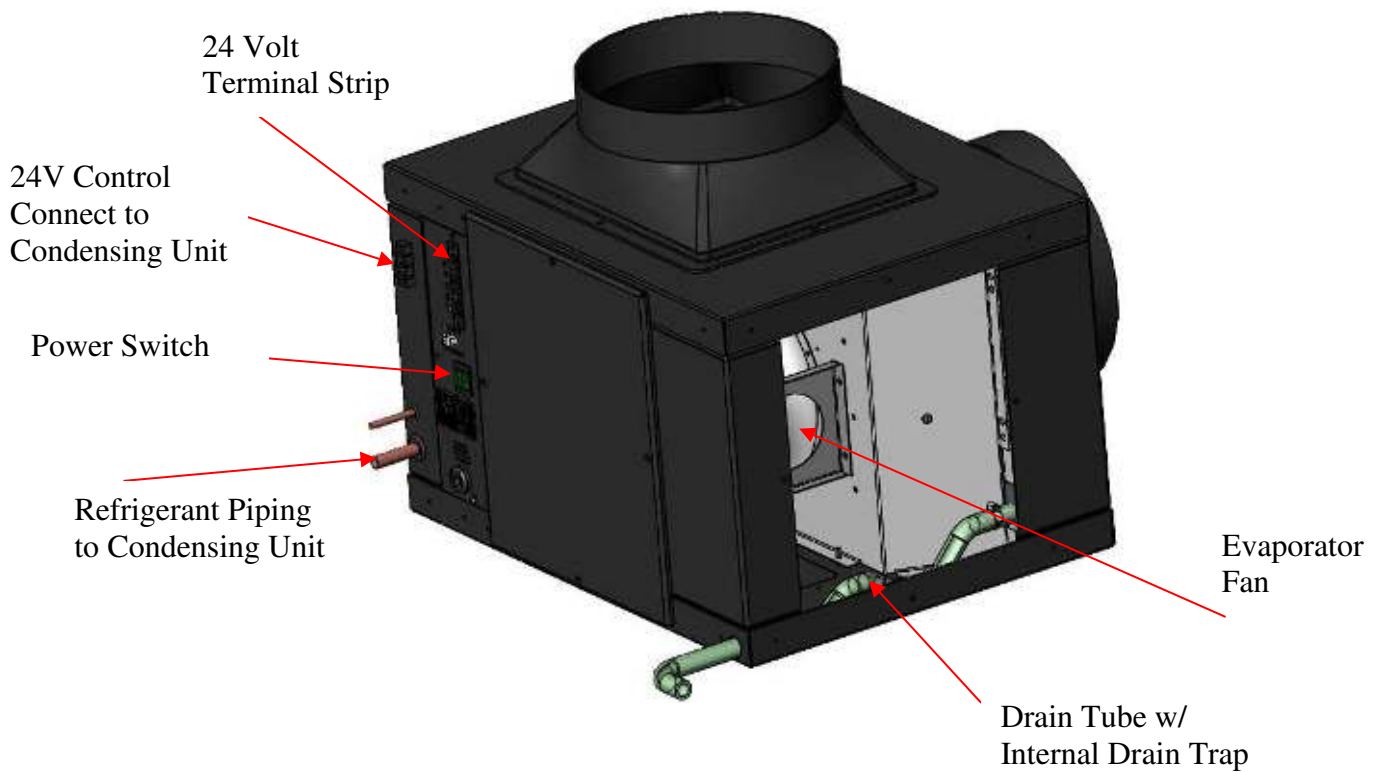
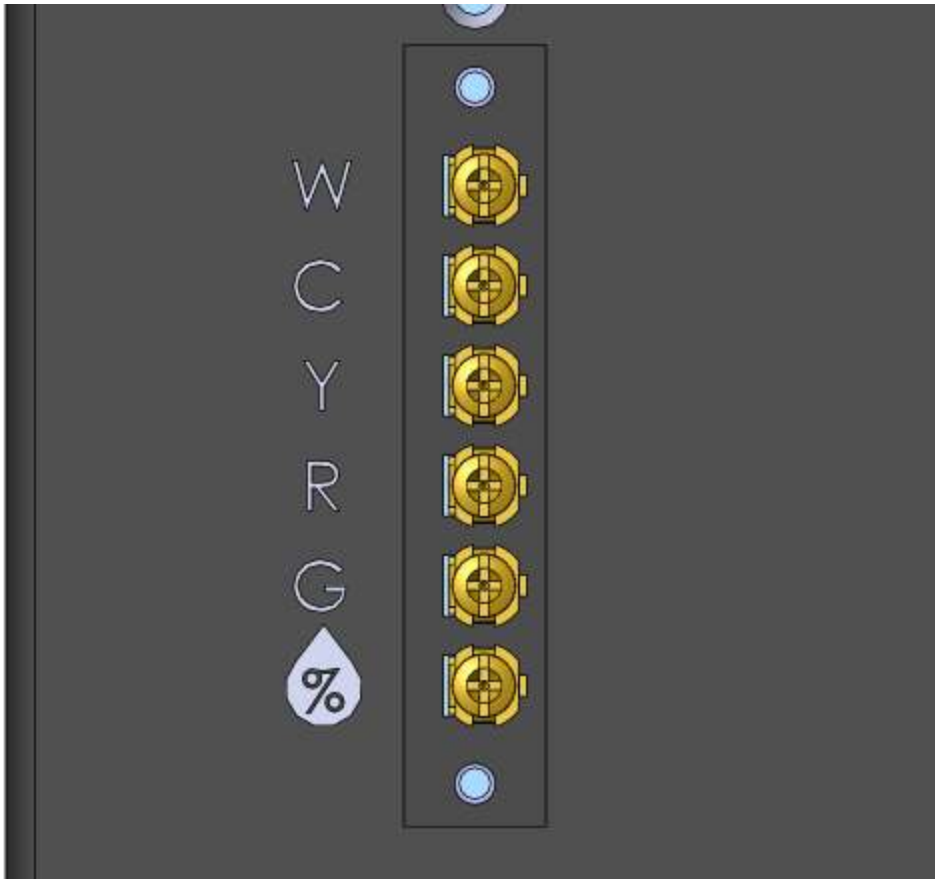

Fig. 2



Terminal Strip Connections



White = Heat

Cyan = 24 Volt AC Common

Yellow = Cool

Red = 24 Volt AC Power

Green = Fan

% = Humidity Connection

Overview of the Wine Guardian PRO SERIES Split System Condensing Unit

Fig. 3

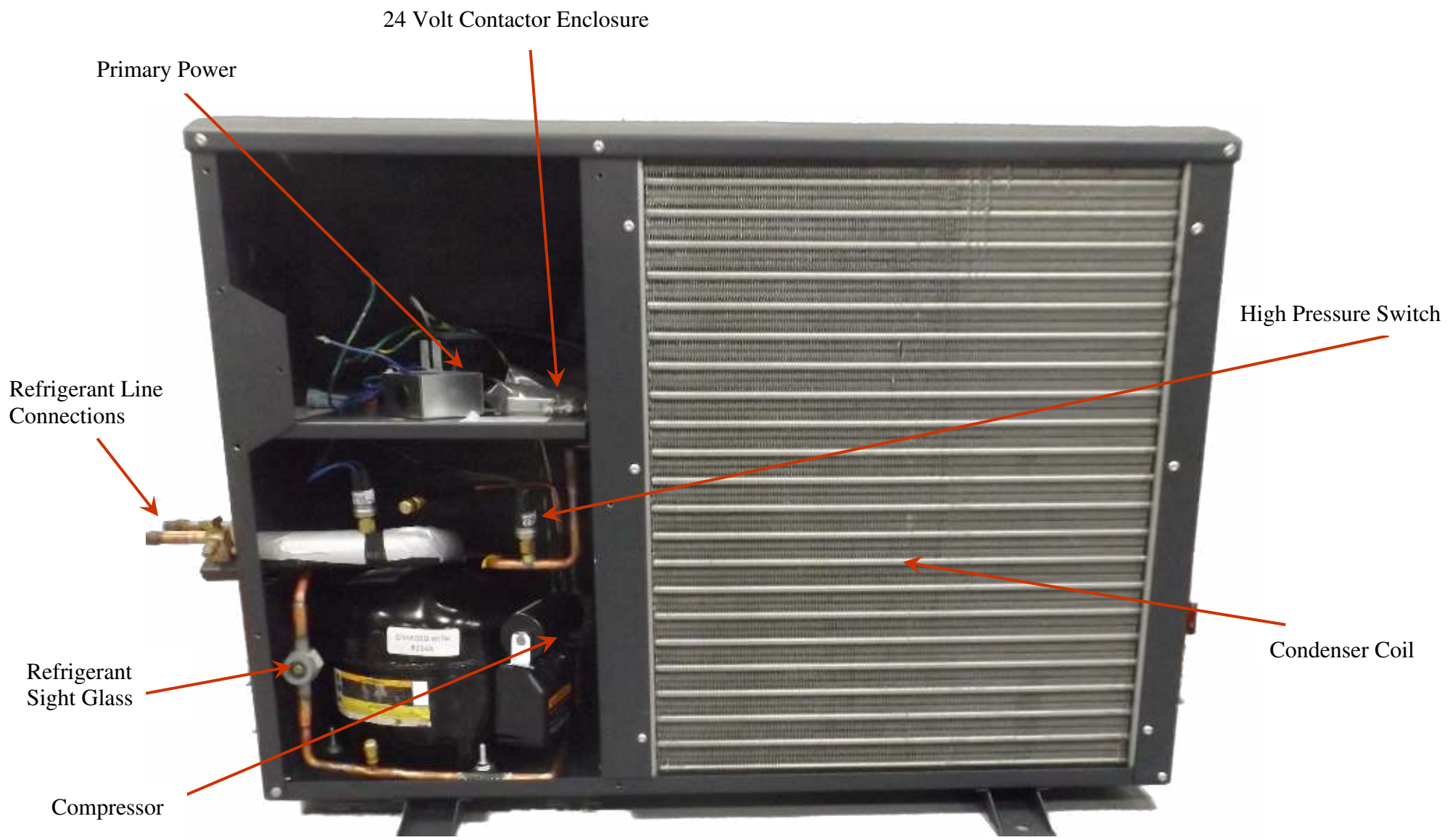

Fig. 4

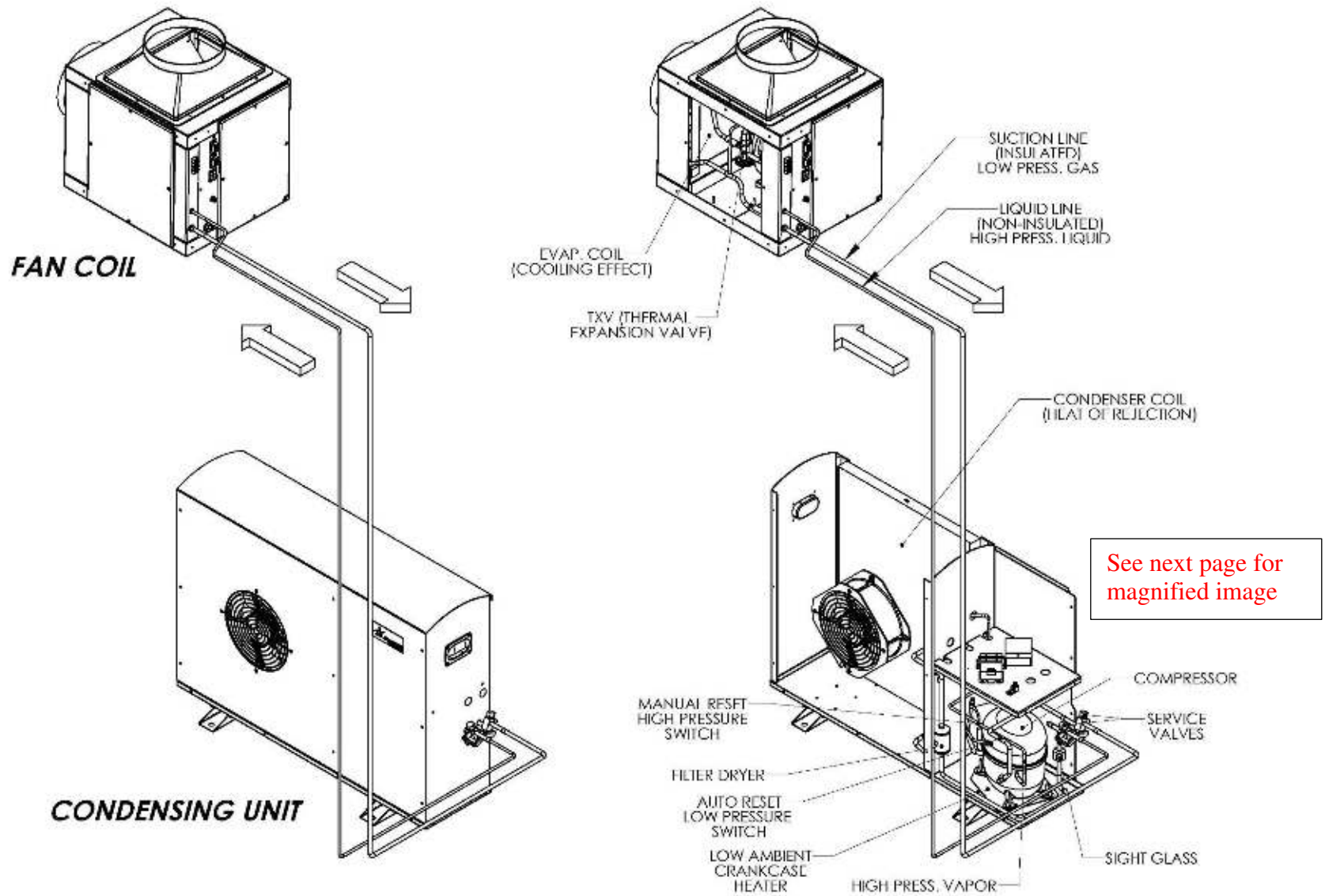
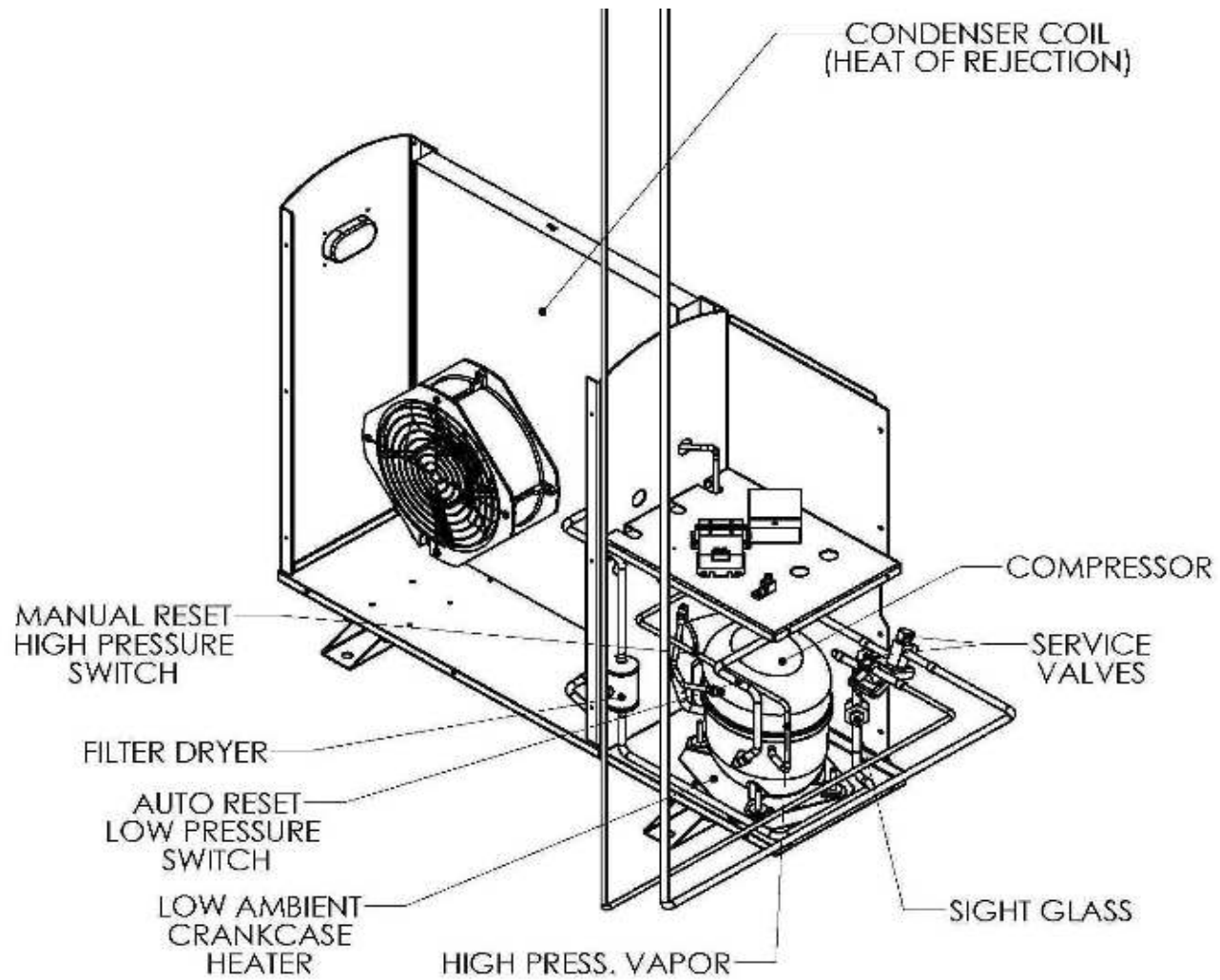

Fig. 5



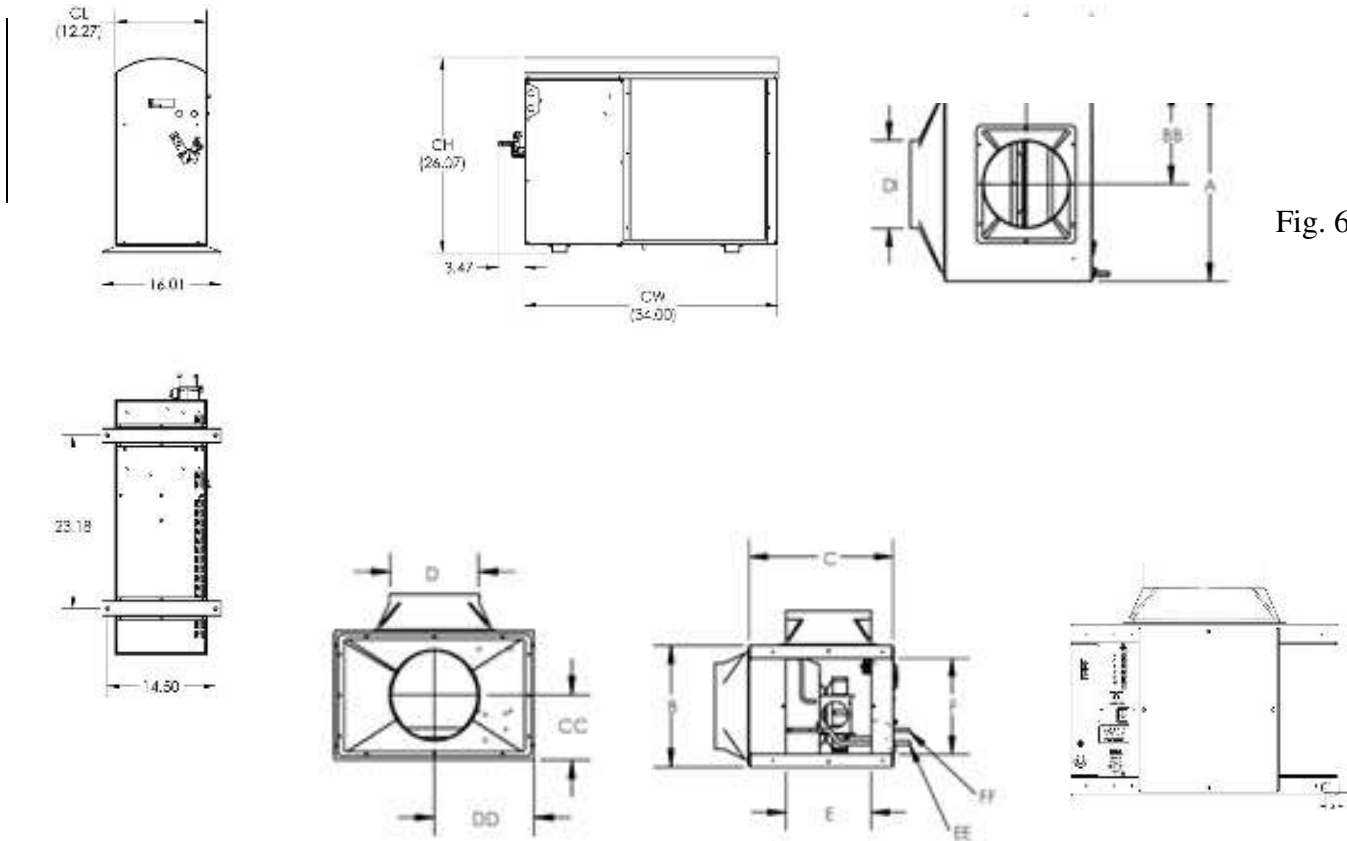



Fig. 6

| Model Number | | SP25 | SP50 | SP88 | SP200 |
|-------------------------------|-------------|--------|--------|--------|--------|
| Dimensions - Nominal | | | | | |
| A – Width | Inches | 14.00 | 22.00 | 22.00 | 22.375 |
| B – Height | Inches | 14.132 | 14.132 | 14.132 | 18.00 |
| C – Length | Inches | 16.75 | 16.75 | 16.75 | 20.50 |
| D – Evap. Discharge (OD) | Inches | 7.94 | 9.938 | 9.938 | 11.94 |
| DI – Evap. Inlet (OD) | Inches | 7.938 | 9.938 | 9.938 | 11.94 |
| E – Outlet opening width | Inches | 9.980 | 10.00 | 10.00 | 11.63 |
| F - Outlet opening height | Inches | 11.13 | 11.13 | 11.13 | 15.00 |
| G – Drain outlet location | Inches | 0.656 | 0.919 | 0.919 | 0.848 |
| AA – Discharge opening height | Inches | 7.50 | 7.50 | 7.50 | 9.188 |
| BB – Discharge opening width | Inches | 7.00 | 11.00 | 11.00 | 11.188 |
| CC – Inlet opening height | Inches | 7.066 | 7.066 | 7.066 | 9.00 |
| DD – Inlet opening width | Inches | 7.00 | 11.00 | 11.00 | 11.188 |
| EE – Suction Line (OD) | Inches | 0.375 | 0.500 | 0.500 | 0.500 |
| FF – Discharge Line (OD) | Inches | 0.250 | 0.250 | 0.250 | 0.375 |
| Weight | Lbs. | | | | |
| CH – Condenser Height | Inches | 26.07 | 26.07 | 26.07 | 26.07 |
| CL – Condenser Length | Inches | 12.27 | 12.27 | 12.27 | 12.27 |
| CW – Condenser Width | Inches | 34.00 | 34.00 | 34.00 | 34.00 |

Table 1

Wine Guardian PRO SERIES Split System Specifications sheet

|  | | SPECIFICATIONS WG PRO SPLIT SERIES | | | |
|---|---------------|---|----------------------------|----------------------------|----------------------------|
| Model Number | | -SP25 | -SP50 | -SP88 | -SP200 |
| Power Requirements | volt/phase/hz | Total/Sensible @208/230V | Total/Sensible @208/230V | Total/Sensible @208/230V | Total/Sensible @208/230V |
| Performance (57°/55%RH) | | | | | |
| Net Cooling Capacity* | | Total/Sensible | Total/Sensible | Total/Sensible | Total/Sensible |
| @10 Deg F condenser inlet air | BTUH | 4190/3178 BTUH | 5535/4203 BTUH | 10795/8810 BTUH | N/A |
| @40 Deg F condenser inlet air | BTUH | 3793/3178 BTUH | 6458/5023 BTUH | 10895/8815 BTUH | 17118/11173 BTUH |
| @90 Deg F condenser inlet air | BTUH | 3485/3075 BTUH | 6785/5330 BTUH | 10455/8405 BTUH | 17425/11173 BTUH |
| @80 Deg F condenser inlet air | BTUH | 3485/3178 BTUH | 6458/5023 BTUH | 9840/7888 BTUH | 15785/10455 BTUH |
| @100 Deg F condenser inlet air | BTUH | 3178/2189 BTUH | 5700/4510 BTUH | 8225/7075 BTUH | 14145/9738 BTUH |
| @115 Deg F condenser inlet air | BTUH | 2873/2693 BTUH | 5128/3783 BTUH | 6713/5683 BTUH | 12938/8815 BTUH |
| Controls | | | | | |
| Type | | 24 Volt Control - (Thermostat by others) | | | |
| Temperature Accuracy/RH% Accuracy | | N/A Dependant Upon Controller | | | |
| Evaporator Section | | | | | |
| Fan Motor Size | Rated Watts | 90 Rated Watts | 110 Rated Watts | 220 Rated Watts | 180 Rated Watts |
| Rated Air Flow (free blow) | CFM | 236 CFM | 410 CFM | 482 CFM | 759 CFM |
| Rated Air Flow @ pressure loss | CFM | 226 @ 0.10" w.c / CFM | 368 @ 0.20" w.c / CFM | 457 @ 0.20" w.c / CFM | 728 CFM @ 0.35" w.c / CFM |
| Heat | | | | | |
| Type | | Electric | Electric | Electric | Electric |
| Capacity | Watt | 1000 Watts | 1000 Watts | 2000 Watts | 2000 Watts |
| Humidifier (Option) | | | | | |
| Type | | Removable drip pad with integral fan | | | |
| Capacity - water temp of 90 Deg F | lbs./hr | 0.42 | | | |
| Capacity - water temp of 80 Deg F | lbs./hr | 0.67 | | | |
| Capacity - water temp of 120 Deg F | lbs./hr | 1.11 | | | |
| Electrical Requirements | | | | | |
| Power | volt/phase/hz | 115 Volts/1 phase/60Hz | 115 Volts/1 phase/60Hz | 208-230Volts/1 phase/60Hz | 208-230Volts/1 phase/60Hz |
| Current Draw - Cooling mode | Amps | 0.8 Amps | 3.0 Amps | 0.8 Amps | 0.8 Amps |
| Current Draw - Heating mode | Amps | 9.4 Amps | 9.6 Amps | 9.5 Amps | 9.5 Amps |
| Minimum Circuit Size (w/heat option) | Amps | 11.6Amps | 11.8 Amps | 11.7 Amps | 11.7 Amps |
| Optional Humidifier | Amps | 0.3 Amps | 0.3 Amps | 0.3 Amps | 0.3 Amps |
| Cabinet | | | | | |
| Construction | | Aluminum | | | |
| Finish | | Black - textured epoxy powder coat | | | |
| Weight | lb. | 25 lb. | 35 lb. | 37 lb. | 55 lb. |
| Dimensions - inches | Length | 16.7 inches | 16.7 inches | 16.7 inches | 21.0 inches |
| | Width | 14.0 inches | 22.0 inches | 22.0 inches | 22.0 inches |
| | Height | 14.1 inches | 14.1 inches | 14.1 inches | 16.0 inches |
| Condensate Drain - 1/2" id tubing | Inches | 0.5 inches | 0.5 inches | 0.5 inches | 0.6 inches |
| Condensing Unit | | | | | |
| Nominal Compressor | Amps | 3.1 Amps | 4.8 Amps | 11.3 Amps | 11.3 Amps |
| Fan Motor Size | Watts | 75 Watts | 75 Watts | 150 watts | 150 watts |
| Rated Air Flow (free blow) | CFM | 275 CFM | 375 CFM | 420 CFM | 675 CFM |
| Weight | lb. | 75 lbs | 75 lb | 65 lb | 120 lbs |
| Enclosure | | | | | |
| Construction | | Aluminum | | | |
| Finish | | Powder coated | | | |
| Dimensions | Length (in) | 12.3 inches | 12.3 inches | 12.3 inches | 12.3 inches |
| | Width (in) | 34.0 inches | 34.0 inches | 34.0 inches | 34.0 inches |
| | Height (in) | 26.07 inches | 26.07 inches | 26.07 inches | 26.07 inches |
| Electrical Requirements | | | | | |
| Power | volt/phase/hz | 208/230 Volts/1 Phase/60Hz | 208/230 Volts/1 Phase/60Hz | 208-230 Volts/1 Phase/60Hz | 208-230 Volts/1 Phase/60Hz |
| MCA | Amps | 4.2 Amps | 8.4 Amps | 14.9 Amps | 24.4 Amps |
| Max tri | Amps | 8.0 Amps | 10.0 Amps | 25 Amps | 40 Amps |
| Agency Approval(s) | | ETLe | ETLe | ETLe | ETLe |

1. Net cooling capacity at entering temperature and humidity conditions of 57 Deg F (14 Deg C) and 55% RH at rated airflow. Reduce capacity by 3% for each 10% reduction in evaporator airflow.

2. Wine Guardian reserves the right to make changes to this document without prior notice at its sole discretion.

3. All ratings at sea level.

4. All btuh capacity and airflow (CFM) values shown are at tested 230v applied on 208/230v rated units (Condensing units and larger evaporators). If field application allows 208v applied to the units dual rated, you can generally expect 2.5%-3.0% decreases in values shown.

7000 Performance Drive | North Syracuse, New York 13212 USA
 800-825-3268 | 315-452-7420 | Fax 315-452-7420 | wineguardian.com | info@wineguardian.com
 Rev. 6-2019



Wiring Diagram for SP200 Units

Fig. 6

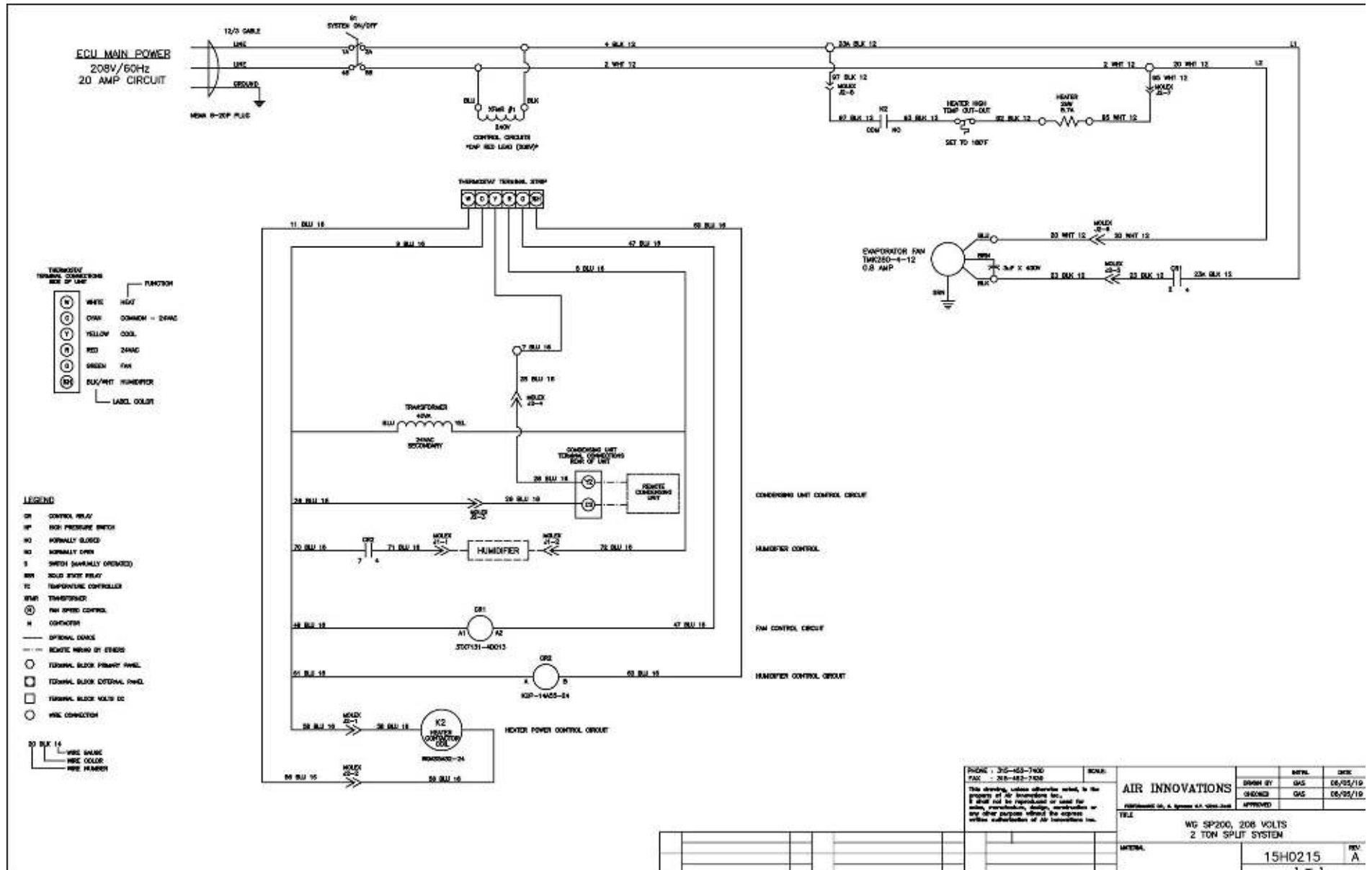

Wiring Diagram Control for SP25 & SP50

Fig. 8

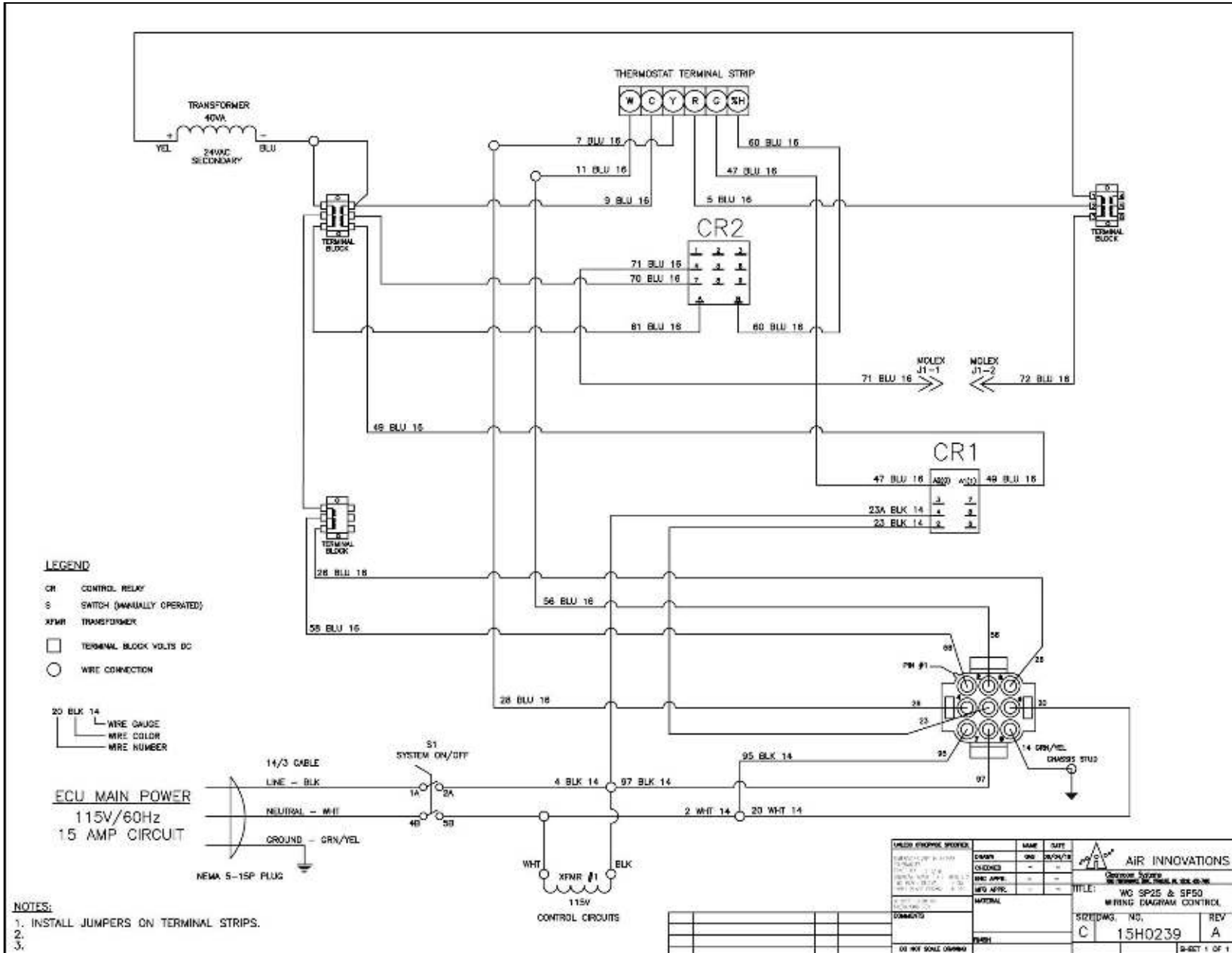

Wiring Diagram Control for SP88

Fig. 9

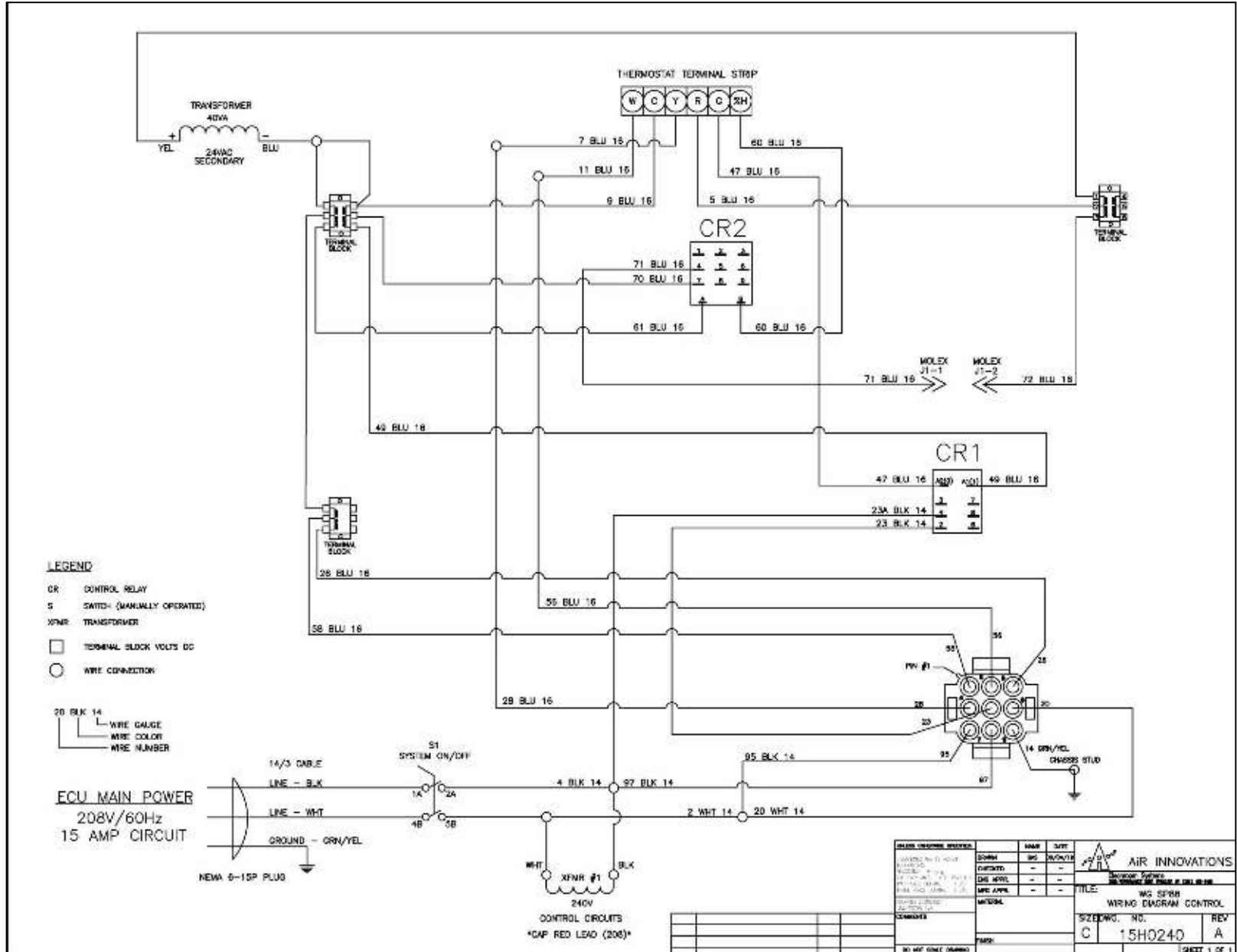

System Wiring Diagram for SP88

Fig. 12

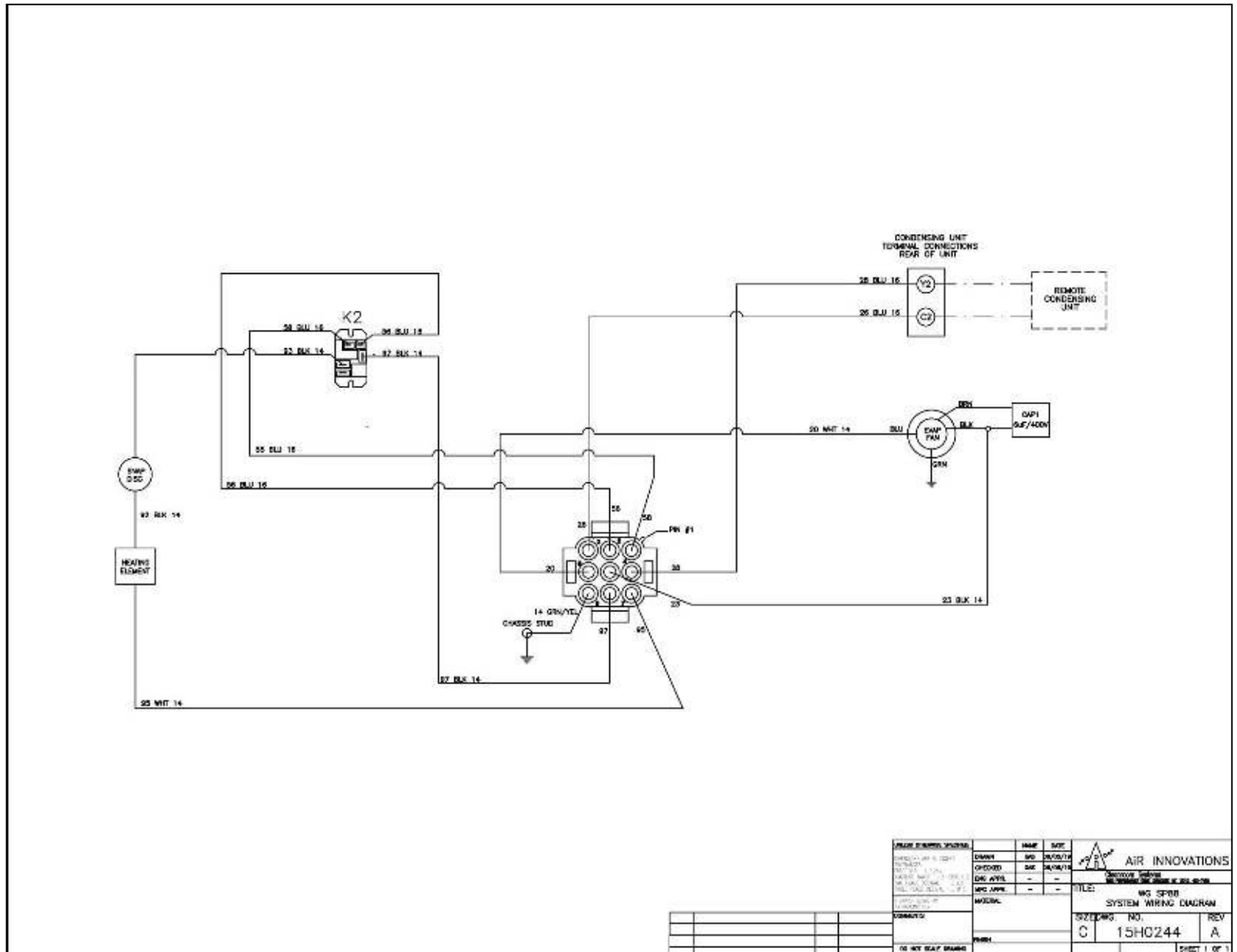

| | | | |
|--|--|---|--|
| APPROVED BY: _____ DATE: _____ CHECKED BY: _____ DATE: _____ DESIGNED BY: _____ DATE: _____ DRAWN BY: _____ DATE: _____ PROJECT NO.: _____ SHEET NO.: _____ | NAME: _____ TITLE: _____ DEPT.: _____ PHONE: _____ FAX: _____ E-MAIL: _____ | DATE: _____ TIME: _____ BY: _____ FOR: _____ PROJECT NO.: _____ SHEET NO.: _____ | AIR INNOVATIONS 15500 W. 15th Ave. #100 Golden, CO 80401 TEL: 303.440.1100 FAX: 303.440.1101 WWW: www.airinnovations.com |
| TITLE: WG SP88 SYSTEM WIRING DIAGRAM | | | SIZE/DWG. NO.: C 15H0244 |
| REVISIONS: | | | REV: A |
| SHEET 1 OF 1 | | | |



System Wiring Diagram for SP200

Fig. 13

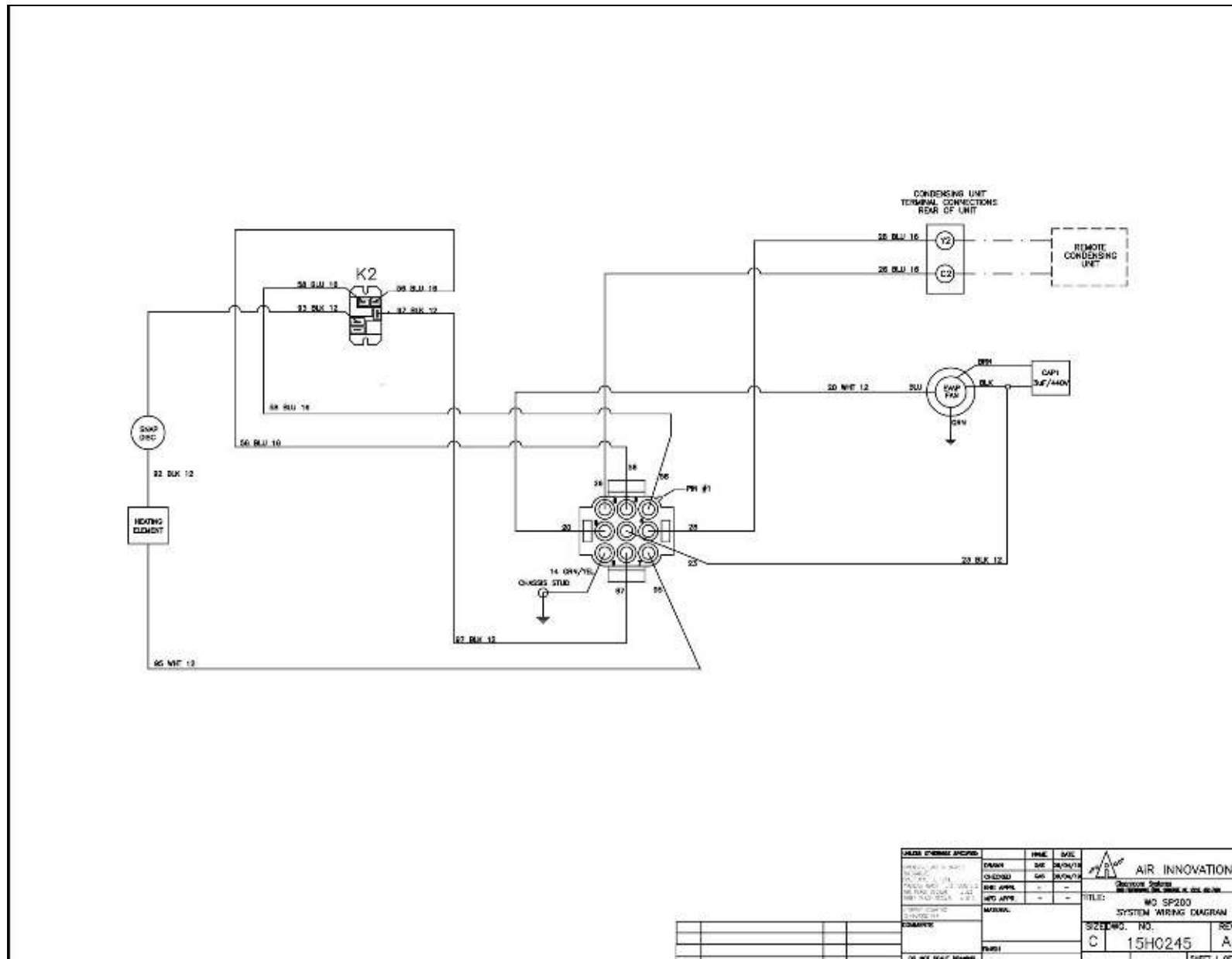

| DATE | DESCRIPTION | BY | CHKD | REV |
|----------|-------------|-----|------|-----|
| 12/10/13 | DESIGN | DAV | DAV | 1 |
| 12/10/13 | CHECKED | DAV | DAV | 1 |
| 12/10/13 | REVISED | DAV | DAV | 1 |
| 12/10/13 | REVISED | DAV | DAV | 1 |
| 12/10/13 | REVISED | DAV | DAV | 1 |
| 12/10/13 | REVISED | DAV | DAV | 1 |

| | |
|--|--------------|
| | |
| AIR INNOVATIONS 20000 SHELBY RD. SUITE 100 WILSON, NC 27157-1000 | |
| TITLE: MG SP200 SYSTEM WIRING DIAGRAM | |
| SIZE: C | REV: A |
| NO. 15H0245 | SHEET 1 OF 1 |

Safety

IMPORTANT

The equipment described in this manual uses electricity. When using this equipment, be sure to follow the safety procedures outlined in this manual.

Safety Message Conventions

Safety messages contained in this manual, DANGER, WARNING, and CAUTION are bold and highlighted in red for quick identification.

Danger

A Danger message indicates an imminently hazardous situation which, if not avoided, results in death or serious injury. Messages identified by the word **DANGER** are used sparingly and only for those situations presenting the most serious hazards.

Following is a typical example of a Danger message as it could appear in the manual:

 **DANGER** 
HIGH VOLTAGE - RISK OF SERIOUS INJURY OR DEATH
High voltages are present in the cabinets.
Before opening panels turn off all power.
Use the Lockout/Tagout procedure.

Warning

A Warning message indicates a potentially hazardous situation which, if not avoided, could result in death or serious injury.

Following is a typical example of a Warning message as it could appear in the manual:

 **WARNING** 
RISK OF PERSONAL INJURY OR DAMAGE TO EQUIPMENT
Modification to the equipment may cause injury.

Caution

A Caution message indicates a potentially hazardous situation which, if not avoided, could result in minor or moderate injury. It may also be used to alert against unsafe practice.

Following is a typical example of a Caution message as it could appear in the manual:

 **CAUTION** 
RISK OF PERSONAL INJURY OR DAMAGE TO EQUIPMENT
Improper installation may result in the equipment malfunctioning and a safety hazard.
Read all of the installation instructions before installing the Wine Guardian PRO SERIES Split System unit.

Lockout/Tagout Procedure

- 1) Turn off the power switch (indicator light should be off)
- 2) Unplug the unit from the electrical outlet and cover the outlet to prevent accidentally plugging in the unit.
- 3) Turn off circuit breaker or disconnect switch at condensing unit.

Safety Considerations

The equipment covered by this manual is designed for safe and reliable operation when installed and operated within its designed specifications. To avoid personal injury or damage to equipment or property when installing or operating this equipment, it is essential that qualified, experienced personnel perform these functions using good judgment and safe practices. See the following cautionary statements.

IMPORTANT
Installation and maintenance of this equipment is to be performed only by qualified personnel who are familiar with local codes and regulations, and are experienced with this type of equipment.

Safety Hazards

Exposure to safety hazards is limited to maintenance personnel working in and around the unit. When performing maintenance, always use the Lockout/Tagout procedure, which is described in this chapter. Observe the maintenance safety guidelines in this manual.

Electrical Hazards

Working on the equipment may involve exposure to dangerously high voltage. Make sure you are aware of the level of electrical hazard when working on the system. Observe all electrical warning labels on the unit.

Electrical Shock Hazards

All power must be disconnected prior to installation and servicing this equipment. More than one source of power may be present. Disconnect all power sources to avoid electrocution or shock injuries.

Hot Parts Hazards

Electric resistance heating elements must be disconnected prior to servicing. Electric heaters may start automatically. Disconnect all power and control circuits prior to servicing the unit to avoid burns.

Moving Parts Hazards

The Motor and Blower must be disconnected prior to opening access panels. The motor can start automatically. Disconnect all power and control circuits prior to servicing to avoid serious injuries or possible dismemberment.

The fans are free-wheeling after the power is disconnected. Allow the fans to stop completely before servicing the unit to avoid cuts or dismemberment.

Rotating Fan Blades are present in the Wine Guardian PRO Split System. Sticking a hand into an exposed fan while under power could result in serious injury. Be sure to use the Lockout/Tagout procedure when working in this area or remove the power cord.

Equipment Safety Interlocks

There are no electrical safety lockouts installed within the unit. The power cord attached to the control box must be disconnected from the power sources prior to working on any part of the electrical system.

Main Power Switch

The main power switch is located on the side of the Wine Guardian PRO Split System. (See Fig.1 on page 9) It shuts off the power to the fan coil unit. A separate disconnect switch will be wired to the condensing unit. Both switches must be turned off prior to servicing equipment.

| Energy Type | Electrical |
|---------------------|--|
| Hazard..... | Electrocution, electrical burns and shock |
| Magnitude | 120 VAC and 230 VAC, 1phase, 60 hertz cycles |
| Control Method..... | Disconnect power cord and On/Off switch |



- **Never** reach into a unit while the fan is running.
- **Never** open an access door to a fan while the fan is running.
- **Disconnect** the power cord switch before working on the unit. The unit may have more than one power source to disconnect.
- **Avoid** risk of fire or electric shock. **Do not** expose the unit to **rain** or **moisture**.



- **Check** weights to be sure that the rigging equipment can support and move the Wine Guardian PRO Split System safely. Note any specific rigging and installation instructions located in the Installation section of this manual.
- All supports for the unit **must** be capable of safely supporting the equipment's weight and any additional live or dead loads encountered.
- All supports for the unit **must** be designed to meet applicable local codes and ordinances.
- **Do not** remove access panels until fan impellers have completely stopped. Pressure developed by moving impellers can cause excessive force against the access panels.
- Fan impellers continue to turn (free-wheel) after the power is shut off.



- **Clean** only with a dry cloth.
- **Never** pressurize equipment above specified test pressure. See Wine Guardian PRO Split System Specification sheet on page 14.
- **Do not use the Wine Guardian PRO Split System near water.**
- **Do not** block any supply or return air register or duct. Install in accordance with the instructions in this manual. Do not defeat the safety purpose of the polarized or grounding type plug. A polarized plug has two blades with one wider than the other. A grounding type plug has two blades and a third grounding prong. The wide blade or the third prong is provided for your safety. If the provided plug does not fit into your outlet, consult an electrician for replacement of the obsolete outlet.
- **Protect** the power cord from being walked on or pinched, particularly at the outlet plugs, convenience receptacles, and the point where it exits the unit.
- **Only** use attachments/accessories specified by the manufacturer.
- **Always** operate this equipment from a 120/230 VAC, 1 phase, 60Hz power sources only.
- **Always** ground the outlet to provide adequate protection against voltage surges and built-up static charges.
- **Refer all** servicing to qualified service personnel. Servicing is required when the unit has been damaged in any way.

Installation



RISK OF SERIOUS INJURY
Sharp edges are present inside the Wine Guardian PRO Split System.

Pre-installation Test

Test the system before installing it to check for non-visible shipping damage.

To test the Wine Guardian PRO Split System fan coil section:

- ✓ Set the system on the floor or a sturdy level surface.
- ✓ Plug in the system.
- ✓ Press the on/off switch to see if the control illuminates. This indicates the system has power.
- ✓ **A built-in timer may be present within the controller which prevents short cycling and keeps the system from turning on right away.** After a five-minute period the fan should turn on and start to deliver air. Listen for any unusual noise or vibration.

Air Flow Diagram

Fig. 1

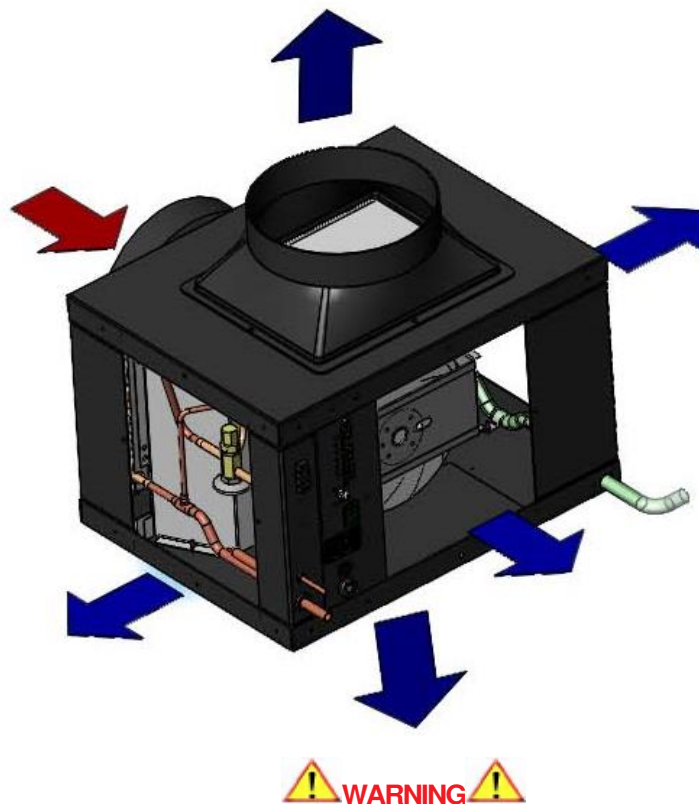

RISK OF PERSONAL INJURY OR DAMAGE TO EQUIPMENT
Modification to the equipment may cause injury or damage to the equipment



- ✓ **This equipment is heavy. Place the unit on the floor or on a level and stable surface that can support the full weight of the unit.**
- ✓ **Do not modify the equipment. Modifications may cause damage to the equipment and will void the warranty.**
- ✓ **Never place anything on top of the unit.**
- ✓ **Never block or cover any of the openings or outlets to the unit.**
- ✓ **Never allow anything to rest on or roll over the power cord.**
- ✓ **Never place the unit where the power cord is subject to wear or abuse.**
- ✓ **Do not use extension cords.**
- ✓ **Never overload wall outlets.**
- ✓ **Do not remove or open any cover unless the unit is turned off and the power cord is plugged in.**
- ✓ **Use only dedicated power outlet boxes of the correct capacity and configuration for the unit model.**



RISK OF PERSONAL INJURY OR DAMAGE TO EQUIPMENT
Improper installation may result in the equipment malfunctioning and a safety hazard. Read all of the installation instructions before installing the Wine Guardian PRO Split System.

[Planning the Installation](#)

IMPORTANT

Installation of residential and commercial split systems must be performed by qualified service technicians with proper training in the installation, start up, service, and repair of these systems. Certification to handle refrigerants is also required.

Addressing Items in the Planning Process

- ✓ Where to locate the fan coil unit? Should it be built into the wine room or mounted remote and ducted into the room?
- ✓ How to mount the fan coil unit?
- ✓ Decide where to locate the supply and return grilles in the room to achieve the temperature gradient and circulation preferred.
- ✓ Locate the electrical power outlet close to the unit. **Do not use an extension cord!**
- ✓ Locate the condensing unit in a clean, dry and well-ventilated area.
- ✓ Where to locate the remote interface controller and/or remote sensors?
- ✓ Where to run the drain line?
- ✓ Are all the parts available to complete the installation?

Performing a Pre-installation Check

- ✓ Check for the proper installation of the electrical plug configuration.
- ✓ Check for the properly sized breakers for both the condensing unit and fan coil section.
- ✓ Is the room built with adequate insulation and vapor barriers?
- ✓ Are ducts installed above the ceiling or in accessible places properly sized before being covered?
- ✓ Is enough space available around the units for service and repair?

Installing the Fan Coil Unit

Wine Guardian PRO Split System fan coil units are typically installed indoors located near the room to minimize the duct runs. Each unit is provided with one entering or return air inlet and five possible supply air outlets. A maximum cumulative total length of flexible ductwork, for

both supply and return ducts (including bends) of 25 feet is recommended. If longer runs are needed, use more than one supply opening to reduce the airflow in each duct by one-half, or install rigid ductwork that is typically less restrictive. Do not exceed 50 feet of total ductwork without using of booster fans. **See Recommended Flexible Ductwork Sizing Chart on page 35.**

Provide a three-foot clearance around the unit for removal of ductwork, or access for unit maintenance. If the humidifier is used, provide access space in front of it for service. (See separate humidifier manual.)

The fan coil unit can be located either above, or below the condensing unit in height. Wine Guardian PRO Split System strongly suggests that any height difference be kept as minimal as possible.

The fan coil unit is equipped with an On/Off switch, 24 volt terminal strip and a humidifier communication port for connection to an optional humidifier.



RISK OF PERSONAL INJURY OR DAMAGE TO EQUIPMENT
Check supporting structure for load bearing capacity to support the Wine Guardian PRO Split System.

All supports must be designed to meet applicable local codes and ordinances.
If in doubt, consult a qualified architect, engineer or contractor.

NOTE: Review Fig. 1 through Fig. 4 on the following pages before mounting the unit.

Floor Mounting

Mount the Wine Guardian PRO Split System fan coil on a plywood surface at least 12 inches above the floor to keep it away from water. Allow adequate space for the external drain.

Wall Mounting

If the unit is mounted onto a wall, provide adequate support on both ends of the unit to accommodate the weight of the system. Use knee braces to transfer the load of the unit to the wall. A shelf can be constructed to support the unit or a wall mount kit can be purchased through a Wine Guardian PRO Split System distributor.

Ceiling Mounting

Construct a structurally sound, level platform to place the unit on when hanging it from the ceiling joists. The Wine Guardian PRO Split System is NOT designed to be suspended from the top of the unit; it must be supported from the bottom. Angle brackets are available as an option for these types of applications. Place the unit on a platform to ensure that the unit is supported on all four corners. Leave adequate space on the top of the unit to remove the access doors for service.

In all cases the unit must be level to within plus or minus one-quarter inch end-to-end and plus or minus one-eighth inch side-to-side for proper operation. Locate the unit as close to the wine room as possible to reduce the length of the duct runs. If possible, use short and straight ducting on all ductwork runs.

Typical Mounting Arrangements

The following illustrations are suggested mounting arrangements. These illustrations are not intended to be complete and detailed installation drawings. For questions or help regarding installation, contact a Wine Guardian PRO Split System distributor or email (info@wineguardian.com) a sketch of the proposed area where the unit is to be installed.

Handling and Installation

- 1) Mount unit on solid, level surface.
- 2) Allow sufficient space for access to unit and accessories.
- 3) Provide proper electrical service.
- 4) Provide water to humidifier.
- 5) Install drain line with proper pitch.

Floor Mount

Supply air at ceiling, low wall return

Fig. 1

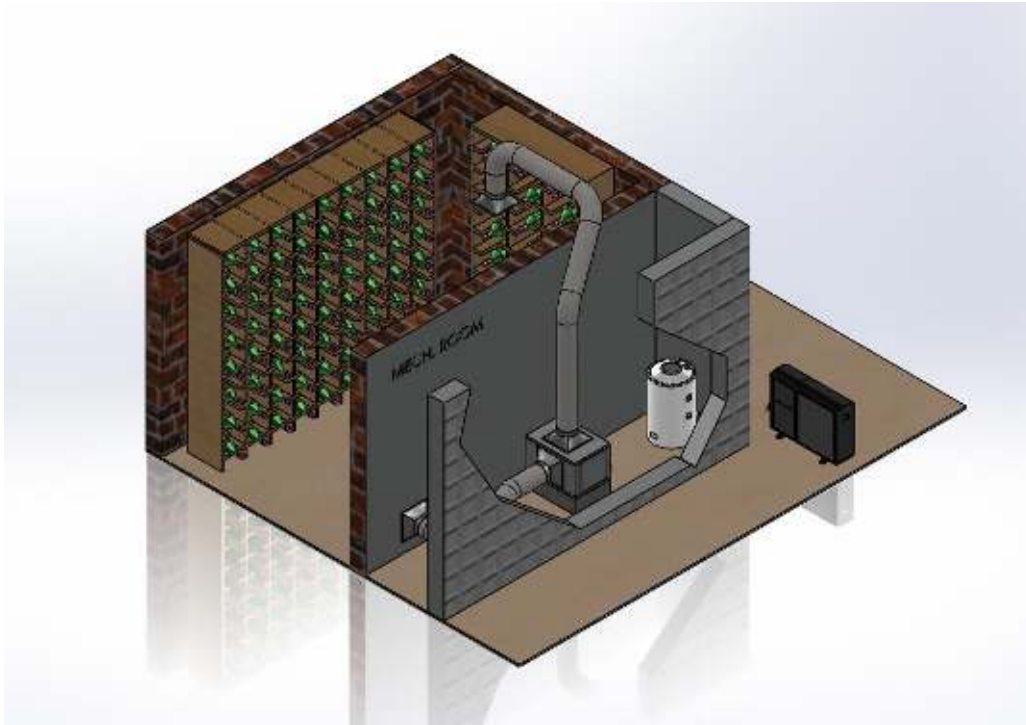

Ceiling Mount

Fig.2

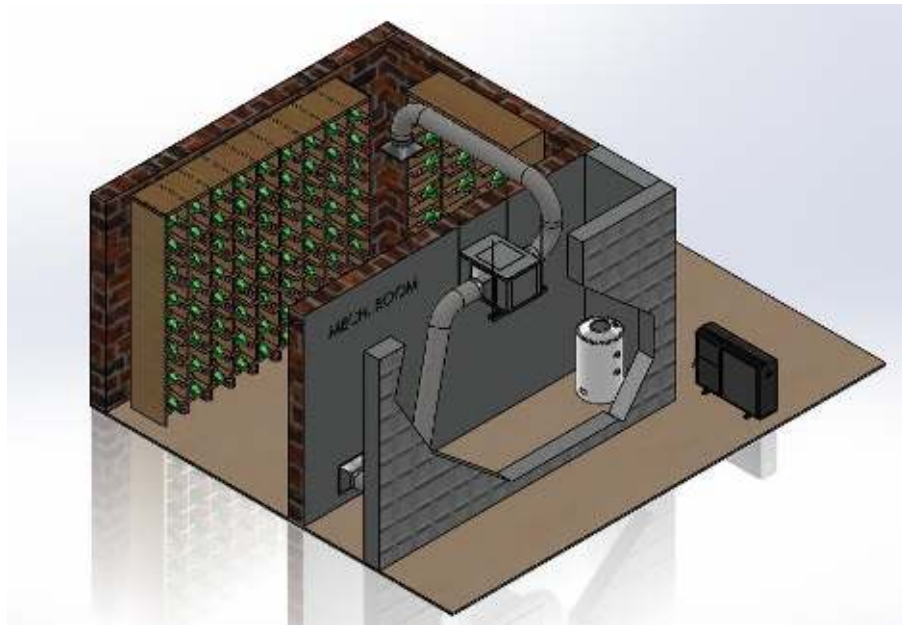

Wall Mount

Fig. 3

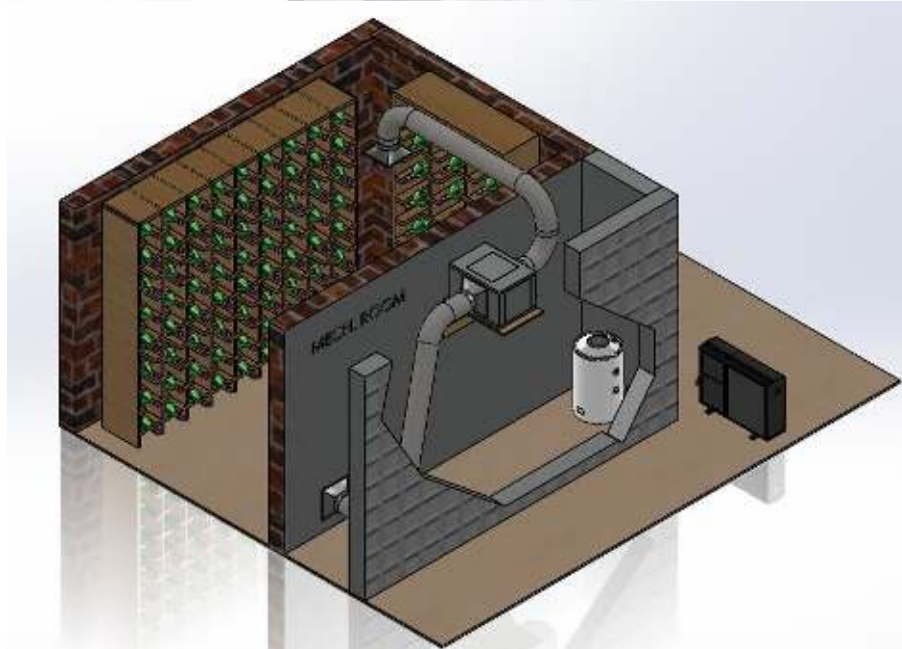

Optional ductwork connection on same wall

Fig. 4

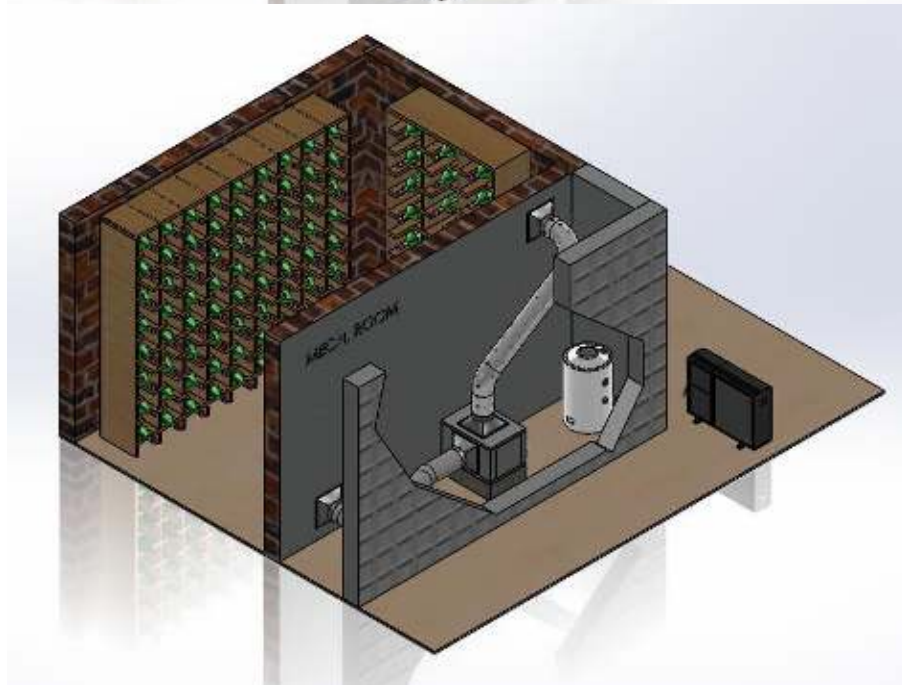

Installing the Ductwork and Grilles

Duct Collars

One inlet duct collar and one evaporator outlet are supplied with each fan coil unit as standard equipment from the factory. The duct collars are removable. The return air, or inlet duct collar must connect to the return air outlet from the wine room. Any of the five supply air outlets on the unit can be used for the ductwork to the supply grille(s) inside the wine room. The factory installed supply duct collar can be relocated to any of the five openings as needed.

Use ductwork to connect the unit to the supply and return outlets in the wine room. Use only insulated ductwork to minimize cooling losses, prevent sweating, and to reduce noise.

NOTE: Do not exceed a total of 25 feet for each length of ductwork run (supply and return).

Table 2

| Recommended Insulated Flexible Ductwork Sizing Chart for the Evaporator (cooling) Coil | | | |
|---|-----------------------------------|-----------------------------------|----------------------------------|
| Model# | Outlet (supply air) Single | Outlet (supply air) Double | Inlet (Return Air) Single |
| SP25 | 8" | 6" | 8" |
| SP50 | 10" | 8" | 10" |
| SP88 | 10" | 8" | 10" |
| SP200 | 12" | 10" | 12" |



CAUTION

RISK OF DAMAGE TO EQUIPMENT

Avoid crimping the flexible ducts. This chokes down the inside area and reduces the airflow, causing the unit to operate erratically.

Be sure all ducts and surface in contact with the airflow are insulated and have a vapor barrier on the outside surface.

NOTE: Uninsulated ducts and surfaces cause bare exposed metal surfaces to sweat, further degradation of the insulation and a loss of equipment cooling capacity.

Location of Supply and Return Grilles

Locate supply and return grilles inside the room to create an airflow pattern that maximizes air circulation in the room. Avoid short circulating of the air.

- ✓ Do not install the return air grilles directly on the floor as the grilles will collect dust from the floor.
- ✓ Do not locate the supply or return air grille where there are blocked by bottles, boxes or cases.
- ✓ Do not locate the supply air grille where it blows directly on the remote interface controller.

General Duct Recommendation

- ✓ Support the flexible duct often to prevent sags or bends.
- ✓ Stretch the duct to make for a smoother interior for less air resistance.
- ✓ For a 90-degree bend, insert a metal elbow inside the flexible duct to avoid crimping.
- ✓ Do not squeeze or reduce the inside diameter of the ducts. This restricts the airflow.
- ✓ Use short and straight ductwork.
- ✓ Review the configuration schematic on the Overview sketch on page 11 for information about which panels are available for duct connections and service.
- ✓ Remove the panels or grilles from the openings to connect the ductwork.
- ✓ Check that all the fan blades move freely.
- ✓ Check for loose foreign objects in any of the air paths.
- ✓ Connect the round flexible ducts to the Wine Guardian PRO Split System using the duct collars provided with the duct accessory kit.
- ✓ Pull the outer plastic wrapping and insulation away from the end of the duct to expose the reinforced inside duct liner.
- ✓ Use tie straps or clamp around the **inside liner** to fasten the duct collar.

NOTE: Do not clamp around the outside insulation. It compresses and loosens over time.

- ✓ Secure the duct collar to the unit using the screws provided. Be careful not to damage or bend the gasket.

Reducing Noise from the Unit

Consider noise when locating the unit close to the room or an adjacent occupied space. A piece of one – or two-inch dense rubber or Styrofoam with foil face in between the unit and the wall absorbs and reduces the noise from the unit. In case of air noise use larger grilles or block the noise with a solid piece of wood or Styrofoam. Sound usually travels as a line of sight. Sound is reduced when it turns a corner, such as passing through a bend in ductwork. If the unit is supported from a wall or joist, place a rubber pad under the unit to reduce vibration transmission.

Installing the Condensate Drain Connection

The Wine Guardian PRO Split System provides dehumidification for the inside of the wine room. It cools the air down to the dew point corresponding to the temperature setpoint of the remote interface controller. If the vapor barrier of the wine room is poorly constructed or excess moisture is in the basement, the unit may remove excessive amounts of moisture from the wine room. The moisture appears in the condensate drain of the unit.

NOTE: If moisture becomes excessive, install a room type dehumidifier to dehumidify the basement so as to not overload your Wine Guardian PRO Split System.

Installing the Drain Line

- ✓ The drain line must extend from the unit to an external drain or disposal point. Do not use drain tubing any smaller than one-half inch inside dimension on the unit.
- ✓ Slide the clear plastic drain tube onto the barbed fitting at the fan-coil unit and secure with a worm gear type clamp.
- ✓ If no drain is available, use a bucket. Do not extend the drain line below the rim of the bucket. Empty the bucket periodically.

The Wine Guardian PRO Split System is provided with a built-in drain trap. The drain trap creates a water seal to prevent air from backing up into the drain pan and causing the drain pan to overflow. Do not create secondary traps in the external drain line.

Allow enough height for the drain line to function properly. If draining into a nearby sink, the unit must be elevated higher than the rim of the sink in order for the water to drain by gravity. Install with a one-quarter inch per linear foot of pitch. **Do not** tie the condensate drain line directly into the sanitary sewer system. See Accessories and Optional Equipment on page 6 for information about the condensate pump.

Priming the Drain Trap

The internal drain trap primes itself automatically once the unit has run for a period of time and after the unit cycles off. This can be confirmed by water dripping from the drain.

Wiring the Fan Coil Unit for Power



DANGER
ELECTRICAL SHOCK HAZARD
RISK OF SERIOUS INJURY OR DEATH

The electrical outlet and wiring installation must meet the national and local building codes.

DO:

- ✓ Match the electrical wiring to the cord provided on the Wine Guardian PRO Split System.
- ✓ Provide dedicated circuit and wiring for the system.
- ✓ Match the wiring and breaker size to the rated load as shown on the serial plate and in this guide. See sample serial plate illustration below.



DO NOT:

- ✓ DO NOT MODIFY THE PLUGS IN ANY WAY!
- ✓ Do not use extension cords.

IMPORTANT
The electrical power supply must be either 115 volt or 230 volt AC 1 phase 60 cycle, depending on the model of the unit, and cannot vary more than plus or minus 4% or damage may occur to the unit.

Plug the unit into the wall outlet. Gently pull on the plug to make sure it is tight.

Required for Models
 SP25, SP50
 -115VAC, 60Hz

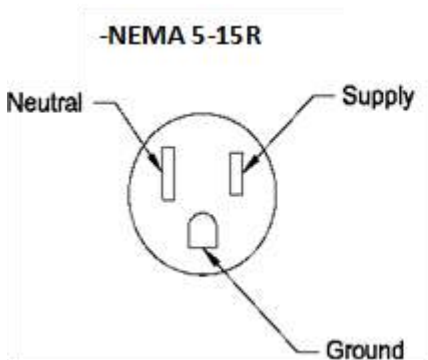

Required for Models
 SP88
 -230VAC, 60Hz

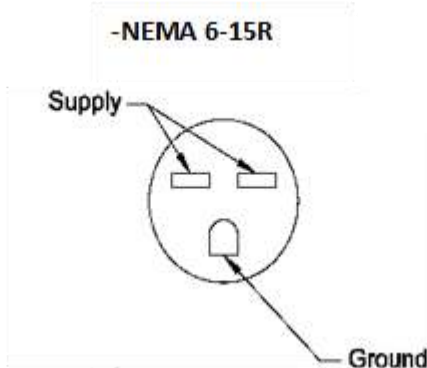

Required for Models
 SP200
 -230VAC, 60Hz

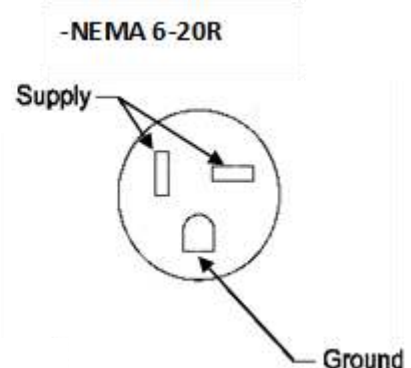

Installing the Condensing Unit

- Condensing units are factory assembled with a sheet metal outdoor hood for protection from the elements.
- A minimum of 12 inches is required around the perimeter of the condensing unit for proper airflow across the coil, and to provide an adequate discharge airflow path through the louver section. Any obstructions to this airflow will result in a decrease in performance, and possibly premature failure due to a buildup of high pressure within the system.
- The condensing unit is designed to operate in ambient temperatures ranging from 20 degrees F to 115 degrees F, as it is supplied with many standard features to assist full operation in this wide range.
- Mount the condensing unit above normal snowfall levels, so as to allow uninhibited winter operation. A build up of snow or any obstruction to airflow will result in a decrease in performance and possible premature failure due to an increasingly high pressure within the system.

Installation of Interconnecting Refrigerant Lines (Suction and Liquid)

NOTE: The interconnecting copper refrigerant lines shall be supplied by the installer. The larger suction line must be fully insulated along its complete length from condensing unit to fan coil unit. There is a factory-installed liquid line filter-drier inside the condensing unit; therefore no additional drier is needed for proper operation. A liquid line moisture/sight glass is factory installed in the condensing unit to assist in monitoring the refrigerant charge, and the state of the refrigerant in the system.

- Keep horizontal and vertical distances between the indoor and outdoor section as close as possible to minimize refrigerant charge required. This will reduce system issues related to oil management that can impair performance and jeopardize the compressor's lubrication.
- Provide a one-inch pitch in suction and liquid line toward the evaporator for every 10 feet of run to prevent any refrigerant that condenses in the suction line from flowing to the compressor when the unit is off. These two lines can be routed together and wrapped together, as long as the suction line is fully insulated as previously directed.
- Suction line riser traps are not required if the riser is properly sized to maintain refrigerant velocity. Adding a trap will only increase pressure drop.
- Prevent dips, sags, or other low spots that will trap refrigerant oil, which is an issue especially with long horizontal runs. Use hard refrigerant copper for longer horizontal runs to prevent potential oil return problems. (see sample piping chart on page 34)
- When sweat connections are made in the connecting lines, be sure that the inside of the compressor suction and discharge valves should be open to atmosphere no longer than 15 minutes. Compressors with POE (polyolester) oil will quickly become contaminated when opened to atmosphere. On any installation, the use of a suction line filter, liquid line filter drier and moisture indicator is recommended. If the suction line is larger than one-quarter inch, a vibration eliminator should be installed close to the motor compressor in a

horizontal parallel to the compressor, crankshaft or in a vertical position 90 degrees to compressor crankshaft.

NOTE: The suction line should be clamped near the inlet end of the vibration eliminator. The vibration eliminator is located between the clamp and the compressor.

Split System Interconnecting Line Sizing Chart

Table 3

| Model | Liquid Line(OD) | Liquid connection at evaporator (OD) | Suction line (OD) | Min. Suction line insulation thickness (in) | Suction connection at evaporator (OD) | Maximum "total" line length | Maximum lift (height) |
|-------|-----------------|--------------------------------------|-------------------|---|---------------------------------------|-----------------------------|-----------------------|
| SP25 | 1/4" | 1/4" | 3/8" | 3/8" | 3/8" | 50' | 15' |
| SP50 | 1/4" | 1/4" | 1/2" | 3/8" | *3/8" | 50' | 15' |
| SP88 | 3/8" | *1/4" | 5/8" | 5/8" | *1/2" | 50' | 15' |
| SP200 | 3/8" | 3/8" | 3/4" | 5/8" | *1/2" | 50' | 15' |

***Interconnecting tube must be reduced down at evaporator connection**

Notes:

- *Line lengths are expressed in equivalent feet = actual run length + fitting allowances (i.e. ~5' for each bend/elbow allowance).*
- *Use only refrigeration grade dehydrated tubing.*
- *Install refrigeration piping per local codes and ASHRAE guidelines.*

Sample Piping Configurations

Incorrect Installation

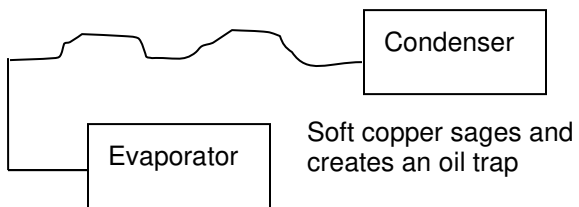
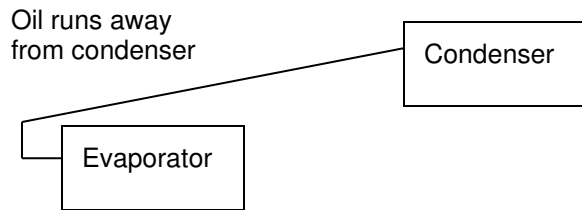
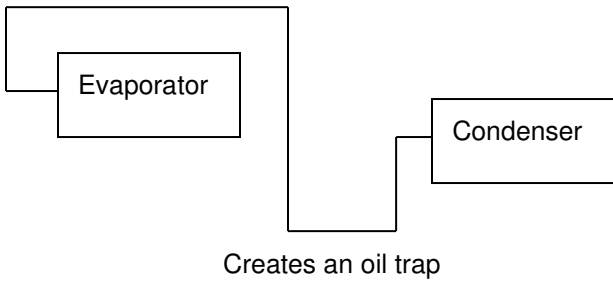
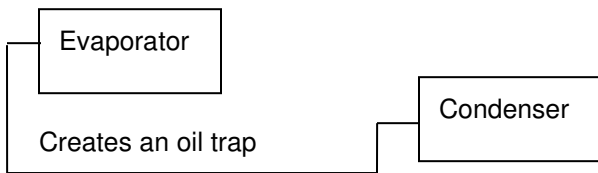

Correct Installation

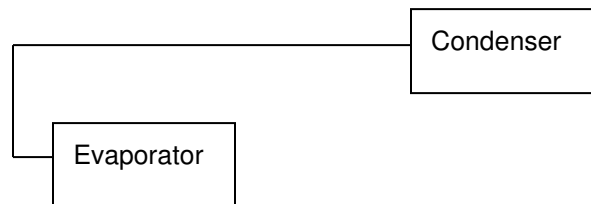
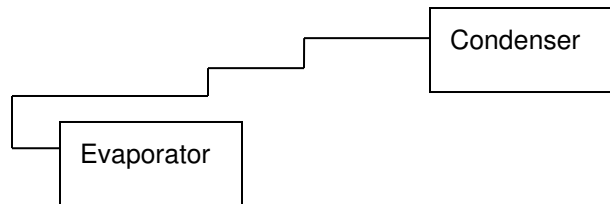
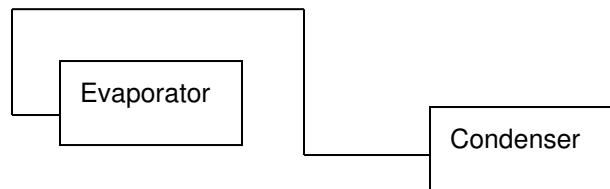
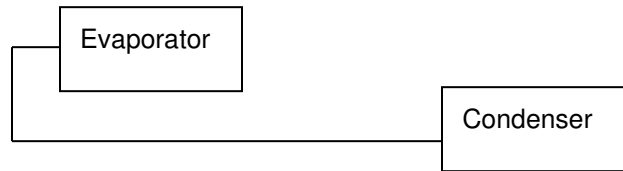

Leak Checking and Evacuation Process



ALL COMPONENTS CHARGED WITH DRY AIR MUST BE EVACUATED BEFORE CHARGING WITH REFRIGERANT

- Purge the dry air charge from the unit by opening the liquid line shut-off valve or removing the liquid line outlet fitting or plug, whichever is applicable for your particular unit. Connect the suction and liquid lines to the unit.
- Pressurize and leak test the entire system including the condensing unit, evaporator and all connecting tubing, fittings, and brazed joints using the intended operating refrigerant for leak testing. A pressure equal to the low side test pressure marked on the unit nameplate is recommended for leak testing. Repair any leaks found. Connect a good vacuum pump to both the low and high side evacuation valves (if provided) with copper tube or high vacuum tube (three-eighths inch inside diameter minimum) and draw a deep vacuum of at least 15pp microns. Do not use the motor compressor to pull a vacuum and do not operate the motor compressor in a vacuum. Break the vacuum with nitrogen.
- Evacuate the system to hold at 500 microns and break the vacuum with refrigerant. Remove the vacuum pump. The system is now ready for charging. Charge the system with the correct amount of refrigerant and mark the amount, with a ballpoint pen, in the space provided on the unit nameplate.

NOTE: When charging through the suction service valve the refrigerant should be charged in vapor form. NEVER CHARGE IN LIQUID FORM. Refrigerant should always be charged through a dryer. Charging in liquid form may damage the valve plate assembly as well as scrub the oil out of the compressor bearings.



NON-AZEOTROPES MUST BE CHARGED IN THE LIQUID PHASE ONLY. TO AVOID COMPRESSOR DAMAGE, LIQUID MUST ALWAYS BE CHARGED INTO THE HIGH SIDE OR INTO AN ACCUMULATOR.

NOTE: Be sure there is not an overcharge of refrigerant. An overcharge might permit liquid refrigerant to enter the motor compressor and damage the valves, rods, pistons, etc.

Wiring

- Wire the system as per the supplied wiring schematic found on pages 15 through 24 of this manual.
- The fan coil unit is powered through a factory-supplied power cord, but you will need to run 24 volt power wires from the two position terminal block to the condensing unit. This can be typical 24 volt thermostat cable or 18 gauge insulated wire. (see Fig.1 on the following page)

Fig. 1



- The condensing unit needs to be hard-wired for the rated high voltage to be brought to the factory-installed contactor in chassis cabinet to the line side (L1 & L2) of the contactor. Use table 1 to identify the minimum recommended AWG, USE COPPER WIRE ONLY. Run a ground lead to be connected to the condensing unit Ground lead/LUG. There is a separate ground lug for the condensing unit internal components. The load side of the factory-installed contactor will be factory-wired.
- Turn on power to the condensing unit 24 hours prior to system start-up to allow crankcase heater to warm up compressor crankcase.

| Unit | Recommended Minimum AWG |
|---------------|-------------------------|
| SP200; WGS175 | 12 |
| SP88; WGS100 | 16 |
| SP50; WGS75 | 16 |
| SP25; WGS40 | 16 |

Refrigerant Charging

NOTE: The SP25, SP50, SP88 and SP200 systems utilize a Headmaster control valve to control head pressure at low ambient applications, therefore require a specific initial charging procedure as outlined below.

Determining the amount of charge – When “refrigerant side” head pressure control is utilized on a system, one of the most important factors is determining the total system refrigerant charge. While on most packaged units the amount of charge is listed on the unit, the required charge for a field built-up system cannot be listed by the manufacturer. Charge is usually added when the system is started up until “proper” system performance is reached. However, this is not

satisfactory and if the system is to function properly year-round, the correct amount of extra charge must be calculated ahead of time.

****SEE PAGE 44 FOR DESIGNED AMOUNTS OF REFRIGERANT CHARGE FOR YOUR SPECIFIC MODEL SYSTEM****

Procedures for Charging System with Head Pressure Control

NOTE: When charging any system with head pressure control the outdoor ambient temperature must be known.

Charging of Systems with Head Pressure Control in ambients above 70 degrees F (After normal evacuation procedures):

1. Connect refrigerant cylinder to a charging or gauge port on the receiver outlet valve.
2. Open the receiver valve approximately one-halfway (so receiver and liquid line are connected to charging or gauge port).
3. Charge liquid refrigerant into the high side of the system. Weighing the charge is recommended.
4. Remove the refrigerant drum and connect it to the suction side of the compressor.
5. Charge refrigerant vapor into the low side. Do not allow **liquid** refrigerant into the low side.
6. Start the system.
7. Observe sight glass (at receiver outlet) to see if system is filling with refrigerant for normal refrigeration cycle.



CAUTION

BUBBLES IN THE SIGHT GLASS CAN BE CAUSED BY FLASHING DUE TO PRESSURE DROP FROM PIPE OR ACCESSORY LOSSES, ETC.

8. If the **Sight glass** shows bubbles, more refrigerant may be required, while allowing sufficient time for the refrigerant to stabilize and clear the **Sight glass**. Use supplied information on the following pages for proper final charge.

Charging of Systems with Sporlan Head Pressure Control in ambient temperature below 70 degrees F (After normal evacuation procedures):

NOTE: When charging in ambient below 70 Deg. F the procedure is very critical. Be sure to adhere to the following steps. Failure to do so will result in overcharging the system.

1. Follow instructions 1 through 7 above.
2. If the valve setting is correct for the system being charged, it is quite likely that some refrigerant will be backed up into the condenser and the **Sight glass** will indicate bubbles in the liquid line.
3. Add more refrigerant, while allowing sufficient time for the refrigerant to stabilize and clear the **Sight glass**. Use supplied information on the following pages for proper final charge.
4. At this point the system is correctly charged for this type of head pressure control at the ambient temperature that exists while the charging procedure is taking place.

5. If the system is designed to operate at ambient below the ambient that exists during charging, additional charge may have to be added now.

Since good system performance during low ambient operation depends on proper refrigerant charge, it is very important that this phase of the installation procedure be done carefully. Many times, poor system performance will be due to too little or too much charge. And in many cases, this will be the last item suspected.

With the system started

- After following instructions on the previous page on initial Charging for Systems with Head Pressure Control, with refrigerant tank now connected to suction line (low side) port to add remaining charge in a gas state, refer to the provided charts for proper system operating points as equated to ambient temperature with wine room at normal conditions of 57 degrees F / 55%RH. Refer to Split Systems Operations chart on page 39 for system pressures, sub-cooling, and superheat values to allow you to charge your system correctly.
- In addition to using the charts provided, there is a liquid line moisture/sight glass located in the condensing (outdoor) unit that will assist you in knowing that you have sufficiently charge your system, HOWEVER a full sight glass or a glass with bubbles does not necessarily mean you are properly charged, or undercharged. There may be other factors affecting sight glass, so do not charge by sight glass method only. A full sight glass- matched with proper system pressures, sub-cooling, and superheat values is the proper method for confirming that the system charge is correct for your application.

If you are not sure how to measure superheat or sub-cooling:

Superheat

- Get an accurate suction line temperature on the suction line as close to the compressor inlet as possible. At same time, attach a compound pressure gauge set to the system so as to read the low side suction pressure at the suction service valve port (back seated valve stem to allow un-restricted refrigerant flow from evaporator back to the compressor). Convert suction pressure to a saturated temperature as derived from a pressure/temperature chart. Since the suction line temperature is the higher value, subtract the saturated temperature from it to derive your superheat. If your wine room is already at specified conditions (e.g., 57 degrees F, 55% RH), and if your superheat is very low, or zero, you may have overcharged your system.

Sub-Cooling

- With your compound pressure gauge set still installed with the high side connect to the valve port on the liquid receiver (back seated valve stem to allow un-restricted refrigerant flow from condenser to evaporator). Convert this liquid pressure to a saturated temperature from pressure/temperature chart. Next, obtain your liquid line temperature by getting an accurate reading on the liquid line BEFORE the TXV expansion on the indoor side. Obtain this temperature entering the evaporator unit. Subtract the liquid line temperature from the saturated liquid temperature to derive the system sub-cooling.

System Charging Amount:

Note: Each SP Model condensing unit is shipped with 16oz of refrigerant charge already, to be taken into account for below total amounts based on 25' interconnect length.

For system charge adjustments compared to 25' factory baseline:

SP25, SP50: 1/4" OD (outside diameter) liquid line, adjustments will be ~ .50oz/foot
SP88, SP200: 3/8" OD (outside diameter) liquid line, adjustments will be ~ 1.0oz/foot

For reference: Suggested total system charge based on factory testing using 25 feet of interconnected piping in table below.

**Based on factory testing using 25 feet of interconnected piping

| | |
|--------------|------------------------|
| SP25 | 59-ounce total charge |
| SP50 | 55-ounce total charge |
| SP88 | 105-ounce total charge |
| SP200 | 108-ounce total charge |

Examples of adjustments:

(Less than 25’): If a SP25 system that is only 15’ (10’ less than factory charge baseline from table above) in total length. At .50oz/foot adjustment, that equals a decrease in total system charge from factory baseline of 5oz. Now a total system charge of 54oz. You then can subtract the initial factory charge of 16oz from this new total, and that is the amount you **ADD** to the system upon start-up.

In this example = 38oz ADDED

(Greater than 25’): If a SP25 system that is 35’ (10’ greater than factory charge baseline from table above) in total length. At .50oz/foot adjustment, that equals an increase in total system charge from factory baseline of 5oz. Now a total system charge of 64oz. You then can subtract the initial factory charge of 16oz from this new total, and that is the amount you **ADD** to the system upon start-up.

In this example = 48oz ADDED

Additional Charge for Xtreme Low Ambient Systems (XLA Option)

For systems that have Wine Guardian’s XLA option installed. Add the following additional charge to the system.

| | |
|---------------------|--------|
| SS018, DS025, DS050 | 4.0 oz |
| WGS25, WGS40, WGS75 | 4.0 oz |
| DS088, DS200 | 6.0 oz |
| WGS100, WGS175 | 6.0 oz |

Once the system has been charged compare the high side system pressure to the “discharge line pressure” found on the “Split System Operations Chart” on page 50 for proper operation. If actual discharge pressures do not match the chart then compare subcooling values as additional charge may be needed.



Split System Operations Chart

SP25

| OD Ambient (F) | Suction (psig) | Discharge (psig) | Superheat (F) | Sub-cooling (F) |
|----------------|----------------|------------------|---------------|-----------------|
| 10 | 21 | 86 | 3 | 15 |
| 40 | 25 | 102 | 9 | 16 |
| 60 | 31 | 105 | 8 | 24 |
| 70 | 31 | 106 | 12 | 24 |
| 80 | 32 | 120 | 16 | 21 |
| 100 | 34 | 164 | 24 | 27 |
| 115 | 35 | 198 | 28 | 35 |

SP50

| OD Ambient (F) | Suction (psig) | Discharge (psig) | Superheat (F) | Sub-cooling (F) |
|----------------|----------------|------------------|---------------|-----------------|
| 10 | 24 | 86 | 5 | 20 |
| 40 | 26 | 102 | 5 | 16 |
| 60 | 28 | 109 | 5 | 17 |
| 70 | 27 | 114 | 11 | 22 |
| 80 | 27 | 134 | 13 | 25 |
| 100 | 27 | 179 | 22 | 30 |
| 115 | 28 | 215 | 27 | 33 |

SP88

| OD Ambient (F) | Suction (psig) | Discharge (psig) | Superheat (F) | Sub-cooling (F) |
|----------------|----------------|------------------|---------------|-----------------|
| 15 | 22 | 98 | 5 | 15 |
| 40 | 23 | 95 | 5 | 17 |
| 60 | 25 | 108 | 8 | 20 |
| 70 | 27 | 130 | 10 | 22 |
| 80 | 28 | 146 | 17 | 24 |
| 100 | 30 | 193 | 20 | 28 |
| 115 | 33 | 230 | 23 | 30 |

SP200

| OD Ambient (F) | Suction (psig) | Discharge (psig) | Superheat (F) | Sub-cooling (F) |
|----------------|----------------|------------------|---------------|-----------------|
| 15 | *25 (avg) | *107 (avg.) | *5 (avg.) | *11 (avg.) |
| 40 | *27 (avg) | *112 (avg.) | *5 (avg.) | *11 (avg.) |
| 60 | 28 | 106 | 8 | 5 |
| 70 | 28 | 123 | 15 | 10 |
| 80 | 29 | 123 | 13 | 10 |
| 100 | 30 | 141 | 14 | 10 |
| 115 | 31 | 210 | 25 | 15 |

Table 4

Inspection and Start Up Checklists

Receiving and Inspecting

- Unit received undamaged
- Unit received complete as ordered including accessories

Handling and Installing

- Unit mounted on solid level surface
- Sufficient space allowed for access to unit and accessories. Proper electrical service provided
- Water provided to humidifier
- Drain lines and trap installed properly
- Ductwork, fittings and grilles installed properly
- All cold duct surfaces insulated
- No obstructions to air flow around condensing unit

Starting-up the Unit

- General visual inspection looks good. All wiring connections checked
- All ducts, grilles and panels in place
- Start unit
- Check ducts and connections for air leaks
- Balance air distribution
- Confirm condenser airflow is unrestricted
- Verify cooling and heating operation
- Check for excessive noise or vibration

Starting-up and Operating the Wine Guardian PRO Split System

Now that the installation is complete, check to make sure all ductwork and electrical connections are secure.

Replace all panels that were removed during installation. Check that all of the openings in the unit are covered with a blank panel, a ductwork connection or a grille.



CAUTION



**RISK OF PERSONAL INJURY
COVER ALL OPENINGS OF THE UNIT TO PREVENT A HAND OR FINGER FROM ACCESS
INSIDE THE UNIT.**

Turn on the Unit

Plug in the unit. Turn on the rocker switch on the side of the unit. The rocker switch lights up to indicate power to the unit. The unit may not come on right away due to the timer built into the circuiting to prevent compressor short cycling.

Testing the Fan

Refer to thermostat manufactures instructions on how to change the fan settings from ON to AUTO.

- ✓ ON means the fan runs continuously and indicates that the power is on and the control circuit is energized and operating.
- ✓ AUTO means the fan runs only when the thermostat is calling for cooling, heating, or the humidistat is calling for humidification.

Running the Unit

- ✓ Check unit to confirm the compressor is running, such as the hum of the compressor or cool air leaving the unit.
- ✓ Check for any unusual noise or vibration, such as clanking or rubbing.

Initially, the unit may run continuously for several hours, up to a day or more, while it lowers the room temperature. Once the unit reaches the setpoint temperature, it shuts off and starts to cycle on and off as it continues to lower the bottle temperature to the setpoint. The room air reaches set point before the bottles. If the room temperature started at 75 degrees the supply air temperature discharged from the unit will probably be 15 degrees to 20 degrees colder. As the room temperature decreases to 55 degrees, the supply temperature differential decreases 8 to 12 degrees colder.

Cycling the Unit

The fans continue to free-wheel for several minutes when the unit cycles off. This is normal. The unit is furnished with a low ambient control, so the condenser fan also cycles on and off during cooling. This maintains the head pressure on the compressor under low ambient conditions and is normal. The bottom of the compressor stays warm even when the unit is off to keep the lubricating oil warm and separated from the refrigerant.

Setting the Thermostat

A 24-volt thermostat/humidistat is not included with the WG Pro Split System and is the responsibility of the purchaser to provide. Please refer to the Operations Manual for your 24-volt thermostat/humidistat for set up and operation.

Regulating the Wine Room Temperature

Wine rooms have a natural temperature gradient of approximately 5 to 10 degrees between floor and ceiling. To increase or decrease the temperature in various zones, change the air flow patterns.

To keep the entire wine room at the same temperature, set the thermostat to run the supply fan continuously and not just when the cooling is operating. Set fan switch to ON instead of AUTO.

NOTE: To monitor the Room Temperature, place thermometers in various locations in the room to monitor the temperature zones. Change the temperature in various zones by shifting the air flow patterns.

Changing the Air Flow Direction

The optional grilles furnished with Wine Guardian PRO Split System are single directional. Rotate the grilles to change the direction of the air flow.

When using multiple supply ductwork, it is necessary to balance the air flow between the ductwork. If too much air flows through one duct but not enough air flows from the other duct, install a damper or other restriction into the duct with too much air. That will force more air to flow out the other duct.

Maintenance

General



BEFORE PERFORMING MAINTENANCE ON THE UNIT, READ AND UNDERSTAND THE SAFETY INFORMATION CONTAINED WITHIN THE SAFETY CHAPTER OF THE WINE GUARDIAN PRO SERIES SPLIT SYSTEM MANUAL.



HIGH VOLTAGE - RISK OF SERIOUS INJURY OR DEATH

HIGH VOLTAGES ARE PRESENT IN THE CABINETS. TURN OFF ALL POWER. USE THE LOCKOUT/TAGOUT PROCEDURE BEFORE OPENING PANELS.



**SHARP EDGES
RISK OF SERIOUS INJURY**

SHARP EDGES ARE PRESENT ON THE FAN WHEELS, HOUSING, FINS AND COILS.

NOTE: Maintenance on Wine Guardian PRO Split System requires working with high voltage and sheet metal with possible sharp edges. Only qualified personnel should perform maintenance. Some tasks require knowledge of mechanical and electrical methods. Make sure you are familiar with all hazards, general safety related procedures, and safety labels on the unit.



EXPOSURE TO MICROBIAL GROWTH (MOLD) CAN CAUSE SERIOUS HEALTH PROBLEMS

NOTE: Standing water in drain pans promote microbial growth (mold) that cause unpleasant odors and serious health-related indoor air quality problems. If mold is found, remove it immediately and sanitize that portion of the unit.

The Wine Guardian PRO Split System is designed for minimum maintenance. The refrigerant system is hermetically sealed and requires no maintenance. The fans are permanently lubricated and require no maintenance. Some maintenance to the unit may be required due to dust or dirt in the air stream.



**SHARP EDGES RISK OF SERIOUS INJURY
SHARP EDGES ARE PRESENT ON THE FINS AND COILS.**

Cleaning the Condensate Drain System

The condensate drain system traps dust and dirt. Clean the drain system once a year.

1. Shut off the rocker switch and unplug the unit.
2. Remove the duct on the evaporator inlet.
3. Inspect the drain pan under the coil.
4. If drain pan appears soiled, pour some hot water mixed with liquid bleach (diluted solution) along the length of the pan to flush the dirt down the drain tube.
5. Continue this treatment until the drain appears clean and free of dirt.
6. Reinstall or duct collar.
7. Plug in the unit and restart.

Cleaning the Humidifier (optional)

If the unit was furnished with a humidifier it requires periodic maintenance. Follow the instructions in the humidifier guide.

Heating Coil Option

The heating coil is located between the evaporator coil and blower inside the transition duct. It contains the heating element and high temperature limit switches. The heating coil is wired to work in conjunction with the remote interface controller. Since the remote interface controller prevents the heating and cooling circuits from being energized at the same time, no additional power wiring is needed. We do recommend using the AUTO mode on the thermostat so it can switch from heating to cooling automatically. If using either the heat or cool only mode, the thermostat will **not** switch automatically.

No additional maintenance is required for the heating coil. To test the heating coil operation, set the thermostat to HEAT and set the temperature above the room temperature. The supply air temperature should start to rise above the return air temperature.

Maintenance Schedule

Monthly

(or quarterly depending on experience with individual room)

- ✓ Check and drain trap – clean if needed.
- ✓ Check for noise or vibration.
- ✓ Check for short-cycling of the unit – a turning on and off of the compressor unit more than eight times/hour.

Yearly

(in addition to monthly)

- ✓ Check evaporator and condensing unit for dirt – use a vacuum with a brush attachment to clean the coils.
- ✓ Clean condensate pan under the evaporator coil by flushing. Be careful to keep the drain pans clear of any and all debris.
- ✓ Inspect cabinet for corrosion or rusting – clean and paint.
- ✓ Inspect for dirt buildup on or inside the unit. Clean unit by vacuuming or wiping it down.
- ✓ Check for loose insulation, fasteners, gaskets or connections.
- ✓ Check the wiring connections and integrity of cords.
- ✓ Examine ducts for any cracks or breach.
- ✓ Check fan and solenoid on humidifier.
- ✓ Replace humidifier pad (if used).

Troubleshooting



BEFORE PROCEEDING, READ AND UNDERSTAND THE SAFETY INFORMATION CONTAINED IN THE SAFETY SECTION OF THE WINE GUARDIAN PRO SERIES SPLIT SYSTEM MANUAL.

IMPORTANT

This section is intended as a diagnostic aid only. For detailed repair or parts replacement procedures, contact a qualified service company. Check the following table for some solutions before calling a service technician.

Typical start up problems

| Possible Cause | Solution |
|--|---|
| Loose, improper or defective thermostat / humidistat cable | Check power, and thermostat or humidistat cable |
| Incorrect thermostat or humidistat (optional) settings | Check the thermostat and optional humidistat setup for the application |
| Changed settings on the thermostat | A common problem is not waiting long enough for the internal timers to complete their timed delay |

Unit does not start up

| Power Switch Light is Off | |
|--|--|
| Possible Cause | Solution |
| Switch not on No power to outlet Unit not plugged in | Turn on switch Check circuit breaker and wiring Plug in the unit |

Power switch light is on and the thermostat is off

| Possible Cause | Solution |
|------------------------|--|
| No power to thermostat | Check for 24 volt power at fan-coil terminal strip Check wiring for loose, broken or frayed connections Check wiring for proper splicing Thermostat may be faulty |

Power switch light is on and the thermostat is on

| Possible Cause | Solution |
|-----------------------------------|---|
| Thermostat is not set up properly | Check thermostat settings in the operations guide Set fan to "ON" to check evaporator fan only |

| <i>Unit is operating and blows evaporator air, but the supply air is not colder than the return air from the room</i> | |
|--|--|
| Possible Cause | Solution |
| Thermostat not set up properly Compressor not operating | Check thermostat setup in the manufactures operations guide High pressure switch open (button up) |
| Condenser airflow is blocked | Remove blockage Clean filter and coil (if needed) Head Pressure (HP) switch is open Reset HP switch See reset instructions on pg. 60 |

| <i>Room temperature too cold (below 51 degrees) when unit is running</i> | |
|---|--|
| Possible Cause | Solution |
| Thermostat set too low on cooling | Reset thermostat to higher cooling temperature |
| Heating coil (optional) not operating | Check for temperature rise across coil |
| Thermostat set too low on heating | Reset thermostat to higher heating temperature |
| Thermostat not controlling temperature | Thermostat mounted in improper location |

| <i>Room temperature too cold (below 51 degrees) when unit is not running</i> | |
|---|--|
| Possible Cause | Solution |
| Too much heat loss to adjacent spaces | Increase insulation around the ductwork Check and clean filter and coil Coil frozen – shut off unit for two hours Install additional insulation |

| <i>Humidity too low or supply air is too cold, without optional humidifier</i> | |
|---|--|
| Possible Cause | Solution |
| Not enough evaporator airflow | Remove blockage in supply or return ductwork Check and clean filter and coil Coil frozen – shut off unit for two hours |
| Defective thermal expansion valve | If under warranty call for service If not under warranty call a refrigeration technician |
| Temperature set too cold | Raise temperature setpoint |

| <i>Humidity too low, without optional humidifier</i> | |
|---|--|
| Possible Cause | Solution |
| No moisture being added to room | Add Wine Guardian PRO Split System humidifier or a room humidifier |

| <i>Humidity too low, with optional humidifier</i> | |
|--|--|
| Possible Cause | Solution |
| Humidifier not operating | Check wiring for loose, broken or frayed connections Check humidistat set up Check for water flow and solenoid valve operation |
| Humidifier operating | Check for water being hot Check drip pad – replace if scaled No vapor barrier around room |

| <i>Humidity too high when unit is running but not cooling</i> | |
|--|--|
| Possible Cause | Solution |
| Compressor not operating | Check and reset high limit switch Clear blockage of condenser airflow |
| Ambient temperature is too high | Reduce temperature or draw condenser air from another space |

| <i>Humidity too high when unit is not running</i> | |
|--|--|
| Possible Cause | Solution |
| Unit not running enough to dehumidify. Or cooling room too quickly and shutting off. | Reduce temperature setpoint. Seal openings around doors (gasket and sweep) |

| <i>Humidity too high when unit is running and cooling</i> | |
|--|---|
| Possible Cause | Solution |
| Too much moisture in room | Poor vapor barrier installation Humidifier malfunction refer to the humidifier instructions Add dehumidifier to surrounding space |

| <i>Unit operates but the power switch light is not ON</i> | |
|--|----------------------------------|
| Possible Cause | Solution |
| Bulb is burned out | Replace bulb |
| <i>Unit is leaking water</i> | |
| Possible Cause | Solution |
| Piping from unit to drain is trapped | Re-pipe to remove external traps |
| Trap plugged | Clean trap |
| Condensate pan plugged | Remove blockage and clean |
| Unit not level | Level with shims |

| <i>Unit is running properly, but the sound of the unit objectionable</i> | |
|---|---|
| Possible Cause | Solution |
| Noise is from airflow | Redirect airflow Add baffles Add insulated ductwork |
| Noise is from unit | Add sound baffle between unit and occupied space |

High Pressure Switch has Shut the Unit Down

Every Wine Guardian PRO Split System has a manual reset high pressure switch in the refrigeration system. This switch shuts the compressor and condenser down if the head pressure in the system is too high. It is intended to protect the compressor. Restricted airflow through the condenser is the most common reason for the pressure becoming too high.

| Possible Cause | Solution |
|--|--|
| Head pressure in unit is too high because an obstruction is restricting air flow | Remove the obstruction at the condensing unit or clean the condenser coil. Then restart the unit after resetting the using the high pressure switch. |

Instructions to Reset High Pressure Switch

1. Remove the top and side access panels at the condensing unit
2. Locate the high pressure switch near the compressor
3. Push in the reset button until it locks into position.
4. Re-install top and side access panels



3

Advanced Troubleshooting

IMPORTANT

This section is intended for qualified refrigeration service technicians only. The technician should repeat all of the previous troubleshooting steps before taking action on these more technical solutions.

Evaporator Coil is Freezing

| Possible Cause | Solution |
|--------------------|---|
| Charge too low | Check sight glass Check for leaks Add refrigerant |
| TXV malfunctioning | Repair or replace |

High pressure switch keeps tripping even after checking for obstructions and dirty filters/coils

| Possible Cause | Solution |
|-----------------------------|-------------------|
| Condenser fan not operating | Repair or replace |
| Defective switch | Replace |

Unit cycles on and off more than 8 times/hr

| Possible Cause | Solution |
|--|--|
| Thermostat malfunction troubleshooting assistance | Check the thermostat operations manual for |
| Low suction pressure | Check low pressure switch Check pressure and adjust superheat |

High pitched or loud rubbing noise, clanking or vibration

| Possible Cause | Solution |
|--------------------------------|-------------------|
| Fans loose or malfunctioning | Repair or replace |
| Excessive compressor vibration | Replace |
| TXV malfunctioning | Repair or replace |

Replacing the blowers

When replacing the fan or motor, replace the fan and motor as a unit. Do not remove the motor from the impeller wheel.

Contact and Warranty Information

Contact Information

Wine Guardian

7000 Performance Drive
North Syracuse, NY 13212
Toll free: (800) 825-3268

Service Department: press 3
Direct: (315) 452-7420
Service Department: ext. 7434

Normal business hours are 8 a.m. to 5 p.m. Eastern, Monday-Friday.
<https://help.wineguardian.com>

Web site: <https://wineguardian.com/>
Email: info@wineguardian.com

Warranty and Warranty Procedure

The Wine Guardian PRO Split System serial number is noted on all packing lists and bills of lading and, along with the shipping date, is kept on file at Wine Guardian PRO SERIES Split System for warranty purposes. **All correspondence regarding warranty must include the model number and serial number of the unit involved.** Note that the warranty is null and void if the serial number on the unit or compressor is altered, removed or defaced. All inquiries or correspondence regarding warranty should be handled in accordance with the “Warranty” and directed to:

Wine Guardian

7000 Performance Drive
North Syracuse, New York 13212
Attn: Service Department
Toll Free: (800) 825-3268
Fax (315) 452-7420

This procedure includes but is not limited to:

- Obtaining authorization from Wine Guardian prior to incurring any charges for repair or replacement under warranty.
- Or returning prepaid within 30 days any and all defective parts.

Warranty

GENERAL

Wine Guardian warrants, to the original buyer, its goods and all parts thereof to be free from defects in material and workmanship for a period of two (2) years from the date of invoicing assuming **NORMAL USE AND SERVICE**.

LIABILITY

Wine Guardian liability shall be limited to the repair or replacement (at its option) of any part, which, at our sole discretion, is determined to be defective. The purchaser shall pay all transportation costs. Additionally, if a malfunction occurs within the first year from the date of invoice, **Wine Guardian** will reimburse the reasonable cost of labor required for the repair or replacement provided authorization is obtained from one of our authorized representatives prior to incurring any labor charges.

LIMITATIONS OF LIABILITY

THESE WARRANTIES ARE MADE IN LIEU OF ALL OTHER WARRANTIES EXPRESSED OR IMPLIED, INCLUDING ANY IMPLIED WARRANTY OF MERCHANTABILITY OR FITNESS FOR A PARTICULAR PURPOSE AND IN LIEU OF ANY OTHER OBLIGATION OR LIABILITY, INCLUDING LIABILITY FOR ANY INCIDENTAL OR CONSEQUENTIAL DAMAGES. **Wine Guardian** will not be responsible for any costs or liabilities whatsoever resulting from improper installation or service of its equipment. In the event that **Wine Guardian** or its distributors are found liable for damage based on any defect or nonconformity in the products, their total liability for each defective product shall not exceed the purchase price of such defective products. No person or representative is authorized to change these warranties or assume any other obligations or liabilities for **Wine Guardian** in connection with the sale of its systems.

INDEMNIFICATION

Purchaser agrees to indemnify, hold harmless and defend seller and its officers, directors, agents and employees from and against any and all claims, liabilities, costs and expenses arising out of or related to Purchaser's use of the goods, or in any way involving injury to person or property or accident occasioned by the goods sold by **Wine Guardian** to Purchaser.

FOREIGN GOVERNMENT AND INDIAN NATIONS

If Purchaser is a foreign government or an Indian nation, Purchaser hereby expressly waives its defense of sovereign immunity in the event of a dispute between Purchaser and **Wine Guardian** regarding this invoice and Purchaser expressly acquiesces to the jurisdiction of the federal and state courts of the United States.

SEVERABILITY

If one or more of the provisions contained in this contract shall for any reason be held to be invalid, illegal or unenforceable in any respect, such invalidity, illegality or unenforceability shall not affect any provision of this contract, but this contract shall be construed as if such invalid, illegal or unenforceable provision had never been contained.

ADDITIONAL REQUIREMENTS

If a defect covered by the Warranty occurs, contact Wine Guardian for authorization to proceed with corrective action. Do not return any parts or incur any charges for which you expect to be reimbursed under this Warranty without receiving this authorization. If parts are replaced under this Warranty, the defective parts must be returned prepaid within 30 days. This warranty shall be null and void in its entirety if the Serial Number on the air conditioner or compressor is altered, removed or defaced.